

QUICK START GUIDE (QSG)

SERIES: ALL

SDRG SEAL INSTALLATION

QSG-122-A

CAUTION:

- CLEAN SEAL FACES WITH AN ISOPROPYL WIPE OR CLEAN LINT FREE CLOTH
- DO NOT TOUCH SEAL FACES WITH BARE HANDS OR DIRTY GLOVED HANDS
- STATIONARY SEALING FACE AND O-RINGS CAN FALL OUT OF SEAL GLAND. WHEN HANDLING, BE SURE THEY DON'T FALL OUT

SDRG SEAL IS SHOWN SEPARATED (AS RECEIVED)

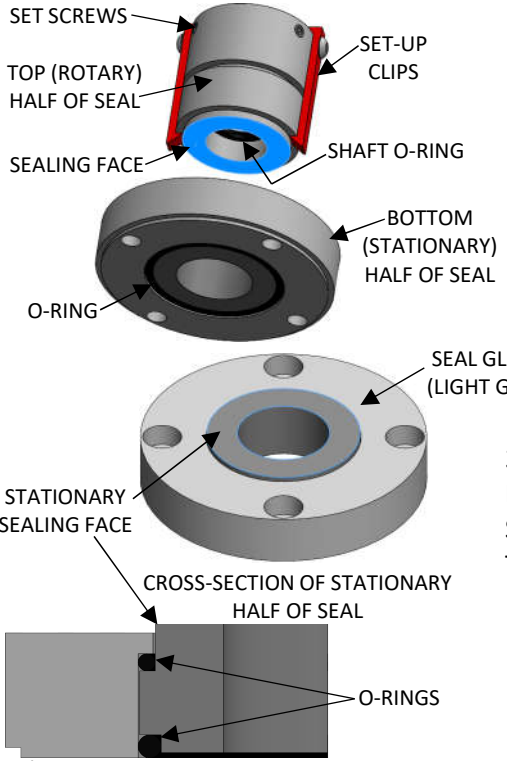

1.) APPLY PROCESS COMPATIBLE LUBRICANT TO THE SHAFT O-RING IN THE TOP HALF OF THE SEAL, BEING CAREFUL NOT TO ALLOW ANY TO MAKE CONTACT WITH THE SEALS MATING SURFACES. BACK OFF THE SET SCREW(S) SO THEY ARE CLEAR OF THE BORE.

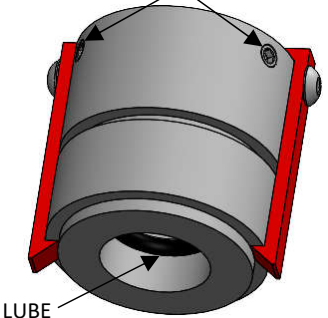

CAUTION
DISCONNECT MIXER FROM POWER SOURCE BEFORE ASSEMBLING, LIFTING, MOVING, OR SERVICING MIXER.

2.) PLACE A U-SHAPED PIECE OF CARDSTOCK (SEE BACK FOR TEMPLATE) BETWEEN THE STATIONARY HALF OF THE SEAL AND THE PEDESTAL BORE. THIS PREVENTS THE STATIONARY HALF FROM SITTING IN THE PEDESTAL BORE.

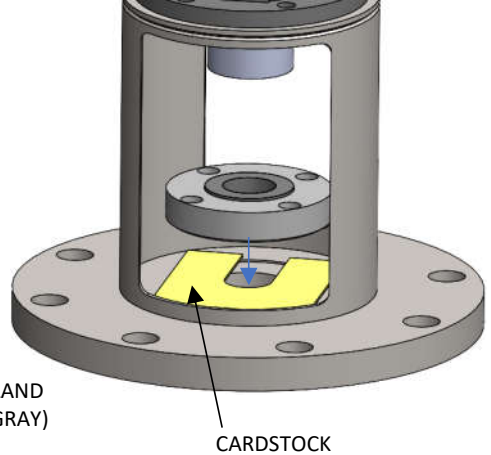

3.) INSERT THE SHAFT THROUGH THE BOTTOM OF THE PEDESTAL, THE STATIONARY HALF OF THE SEAL, AND THE ROTARY HALF OF THE SEAL.

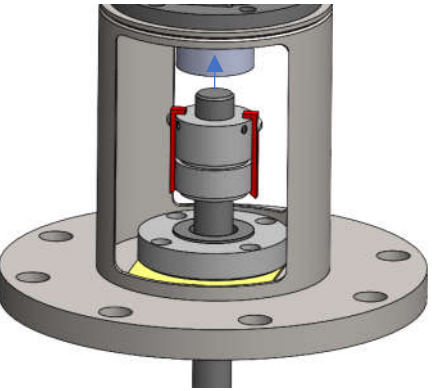

4.) NOW THE ROTARY HALF OF THE SEAL IS "FLOATED" ON THE SHAFT. ATTACH THE SHAFT TO THE MIXER DRIVE ACCORDING TO THE APPROPRIATE SHAFT INSTALLATION QSG.

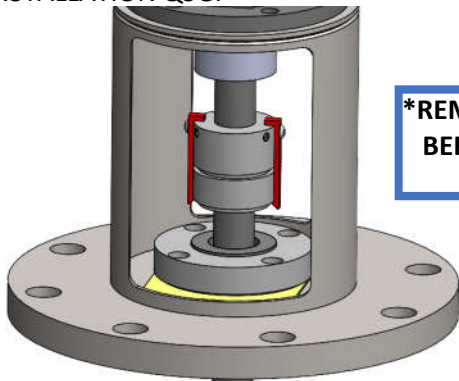

5.) REMOVE THE CARDSTOCK AND PLACE THE STATIONARY HALF INTO THE PEDESTAL BORE, ALIGNING THE HOLES IN THE SEAL TO THE HOLES IN THE PEDESTAL. INSERT AND TIGHTEN THE 4 PROVIDED 5/16" BOLTS TO 103 IN-LB.

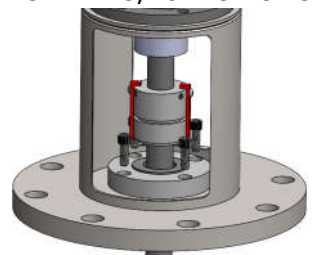

6.) WIPE THE SEAL FACES CLEAN WITH AN ISOPROPYL WIPE AND SLIDE THE ROTARY HALF OF THE SEAL DOWN THE SHAFT UNTIL THE SET-UP CLIPS ARE TOUCHING THE STATIONARY HALF'S SEALING FACE.

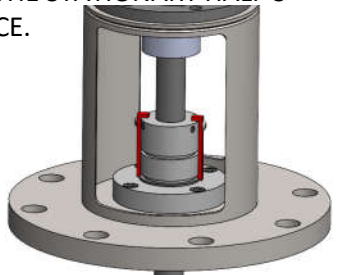

7.) THREAD IN THE SET SCREW(S) IN AN ALTERNATING PATTERN UNTIL THEY ARE BARELY TOUCHING THE SHAFT. DO NOT TIGHTEN ONE FULLY, THEN THE OTHER. ONCE ALL SET SCREW(S) ARE SNUG, TORQUE TO THE APPROPRIATE VALUE IN THE TABLE.

THREAD	18-8 STAINLESS
1/4"-28	72 in-lb.
5/16"-24	147 in-lb.
3/8"-24	22 ft-lb.

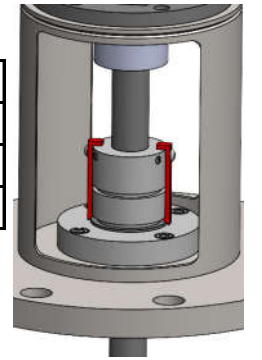

8.) REMOVE THE SET-UP CLIPS AND RETAIN FOR FUTURE USE. THEY WILL BE NEEDED IN THE FUTURE WHEN THE SEAL IS REMOVED.

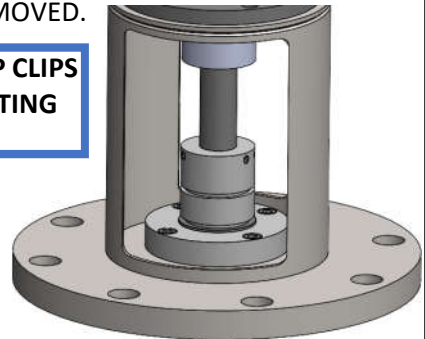

REMOVE SET-UP CLIPS BEFORE OPERATING MIXER

CAUTION:

- THE VISCOSITY AND SPECIFIC GRAVITY OF THE FLUID AFFECTS MIXER SIZING AND SPECIFICATIONS

USE THIS TEMPLATE TO CUT OUT THE U-SHAPED
CARDSTOCK. DO NOT CUT THIS PIECE OF PAPER (QSG).
MAY NEED TO TRIM TO FIT INTO PEDESTAL.

