

# QUICK START GUIDE (QSG)

SERIES: PRO

## ANGLE RISER MOUNT INSTALLATION

QSG-116-A

1.) MAKE SURE THE MIXER MOUNTING LOCATION WILL SUPPORT THE MIXER DURING OPERATION. IT'S RECOMMENDED TO MOUNT THE MIXER WITHOUT THE SHAFT TO AVOID DAMAGE TO THE SHAFT, IMPELLER, OR TANK.

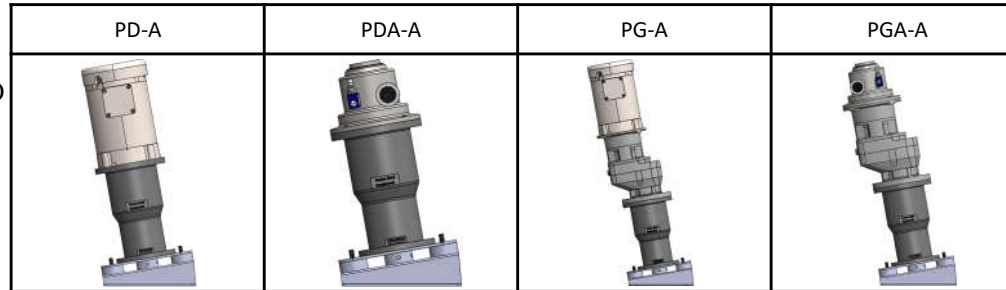

DO NOT LAY MIXER ON SHAFT

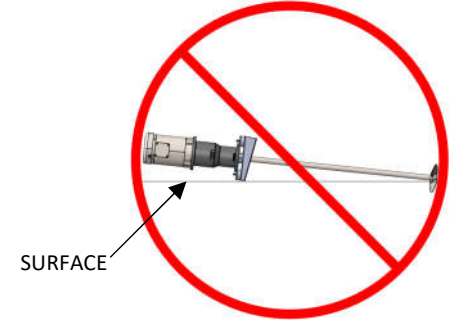

2.) IN GENERAL, FOLLOW THE GUIDELINES IN THE TWO IMAGES BELOW FOR WHERE TO MOUNT THE MIXER IN RELATION TO YOUR TANK. ENSURE THERE'S AT LEAST 3 TIMES SHAFT DIAMETER CLEARANCE BETWEEN THE IMPELLER(S) AND SIDE WALL OF THE TANK ONCE THE SHAFT AND IMPELLER(S) ARE INSTALLED.

3.) PLACE THE MIXER IN THE DESIRED LOCATION AND SECURE WITH 4 BOLTS, NUTS, AND WASHERS (HARDWARE NOT INCLUDED). ONCE MOUNTED, INSTALL THE SHAFT AND IMPELLER(S) PER THE IMPELLER INSTALLATION QSG AND APPROPRIATE SHAFT INSTALLATION QSG, IF NOT ALREADY INSTALLED.

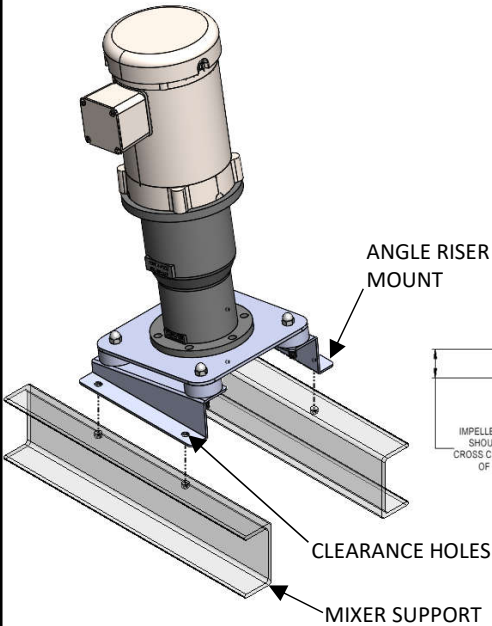

\*THE MIXER SUPPORT NEEDS TO BE RIGID AND CAPABLE OF SUPPORTING THE MIXERS WEIGHT, TORQUE, AND BENDING MOMENT. IF THE MIXER SUPPORT IS NOT RIGID, UNDESIREABLE MOVEMENT WILL OCCUR AND DAMAGE TO THE MIXER AND TANK IS LIKELY.\*

### CAUTION

DISCONNECT MIXER FROM POWER SOURCE BEFORE ASSEMBLING, LIFTING, MOVING, OR SERVICING MIXER.

CAUTION:

- THE VISCOSITY AND SPECIFIC GRAVITY OF THE FLUID AFFECTS MIXER SIZING AND SPECIFICATIONS

