

QUICK START GUIDE (QSG)

SERIES: ALL

BOLTED REMOVABLE RIGID COUPLING

SHAFT INSTALLATION

LINK TO HOW TO VIDEOS



1.) DEBURR AND CLEAN THE BORE AND SHOULDER OF THE MALE REMOVABLE RIGID COUPLING AND THE TURNED DOWN SECTION OF THE SHAFT. ENSURE THE SHAFT SEGMENTS AND RIGID COUPLINGS ARE FOR THE MIXER BEING ASSEMBLED. IF THERE'S ONLY ONE MIXER ON THE ORDER, THEN THE REGISTRATION MARKS ON THE FEMALE AND MALE HALVES WILL LOOK LIKE THE ONES IN THE IMAGE BELOW. IF THERE'S MORE THAN ONE MIXER ON THE ORDER, THEN THE REGISTRATION MARKS ON THE SHAFT COUPLINGS SHOULD ALSO MATCH THE MIXER'S SERIAL NUMBER'S LAST DIGIT (1/1; 2/2; 3/3; ETC...).

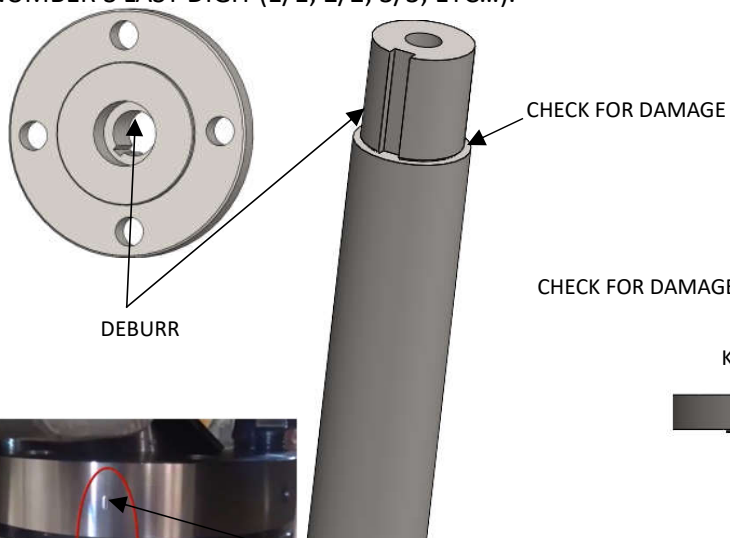

2.) PLACE THE PROVIDED KEY INTO THE KEYWAY ON THE SHAFT. SLIDE THE BOLTED REMOVABLE RIGID COUPLING ONTO THE SHAFT, MAKING SURE THAT THE KEYWAYS ARE ALIGNED AND THE KEY IS SITTING IN THE KEYWAYS.

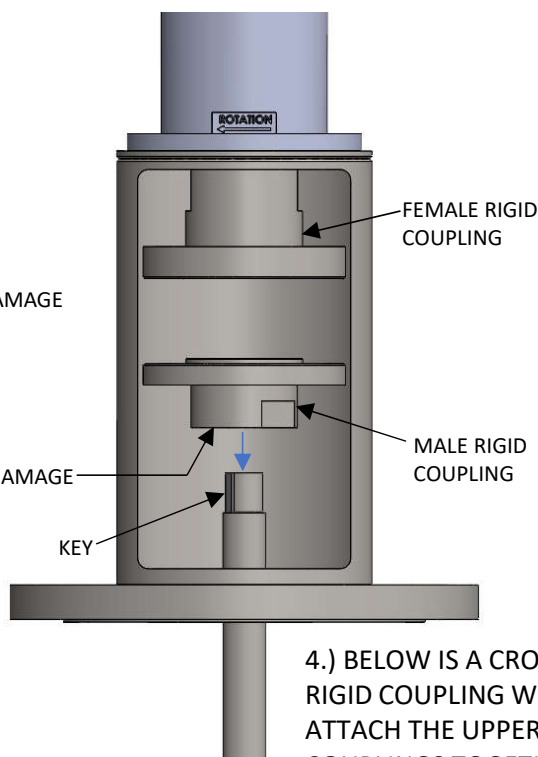

3.) PLACE THE PROVIDED THICK WASHER, THEN THE LOCK WASHER INTO THE BORE OF THE REMOVABLE RIGID COUPLING. PUT SERVICE REMOVABLE THREAD LOCKER ON THE BOLT. INSERT AND TIGHTEN THE PROVIDED BOLT TO THE APPROPRIATE VALUE ON THE TABLE. KEEP THE COUPLING FROM ROTATING WHEN TIGHTENING BY USING WRENCH ON THE COUPLING FLATS, BE CAREFUL NOT TO DAMAGE THE COUPLING.

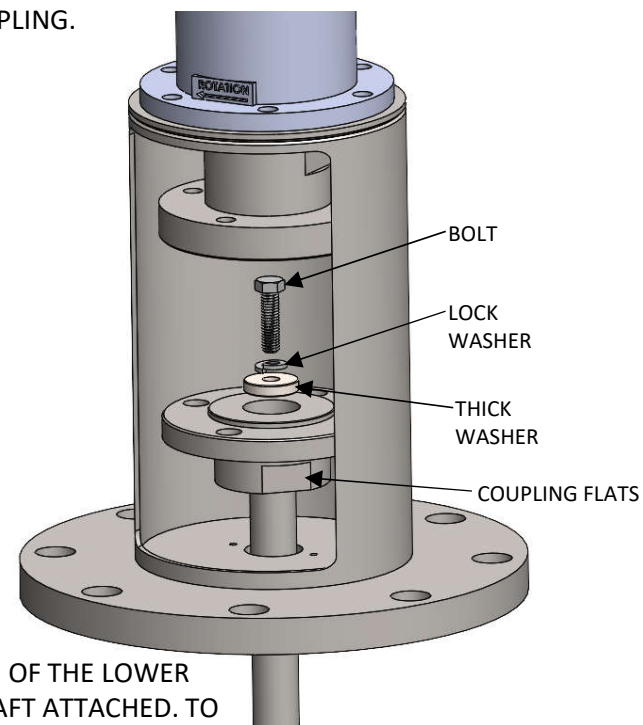

4.) BELOW IS A CROSS-SECTION OF THE LOWER RIGID COUPLING WITH THE SHAFT ATTACHED. TO ATTACH THE UPPER AND LOWER RIGID COUPLINGS TOGETHER, REFER TO THE "RIGID COUPLING SHAFT INSTALLATION" QSG.

MUST BE TIGHT OR THE SHAFT WILL HAVE EXCESSIVE MOVEMENT

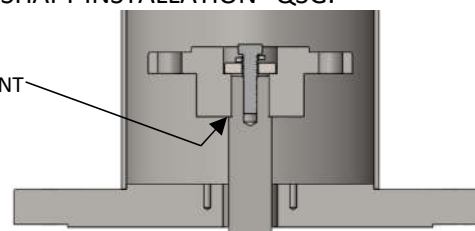

| BOLT SIZE | 316 STAINLESS |
|-----------|---------------|
| 1/4"-20 | 60 in-lb. |
| 3/8"-16 | 17 ft-lb. |
| 1/2"-13 | 38 ft-lb. |
| 5/8"-11 | 84 ft-lb. |

CAUTION

DISCONNECT MIXER FROM POWER SOURCE BEFORE ASSEMBLING, LIFTING, MOVING, OR SERVICING MIXER.

CAUTION:

- THE VISCOSITY AND SPECIFIC GRAVITY OF THE FLUID AFFECTS MIXER SIZING AND SPECIFICATIONS
- DO NOT LAY MIXER ON THE SHAFT