

CAUTION:

- **HEAVY COMPONENTS. HANDLE PROPERLY**
- **DISCONNECT AND LOCK OUT POWER TO MIXER BEFORE SERVICING SEAL**

Begin Seal Installation

If your mixer is equipped with a FSDS mechanical seal, then follow these steps for installation and removal of a piloted seal.

Here is the basic process:

Basic Seal Installation Process

- Insert Bottom (Stationary) Half of Seal
- Float the Seal
- Install the Shaft
- Mount the Seal
- Tighten Set Screws onto Shaft
- Remove Set-up Clips

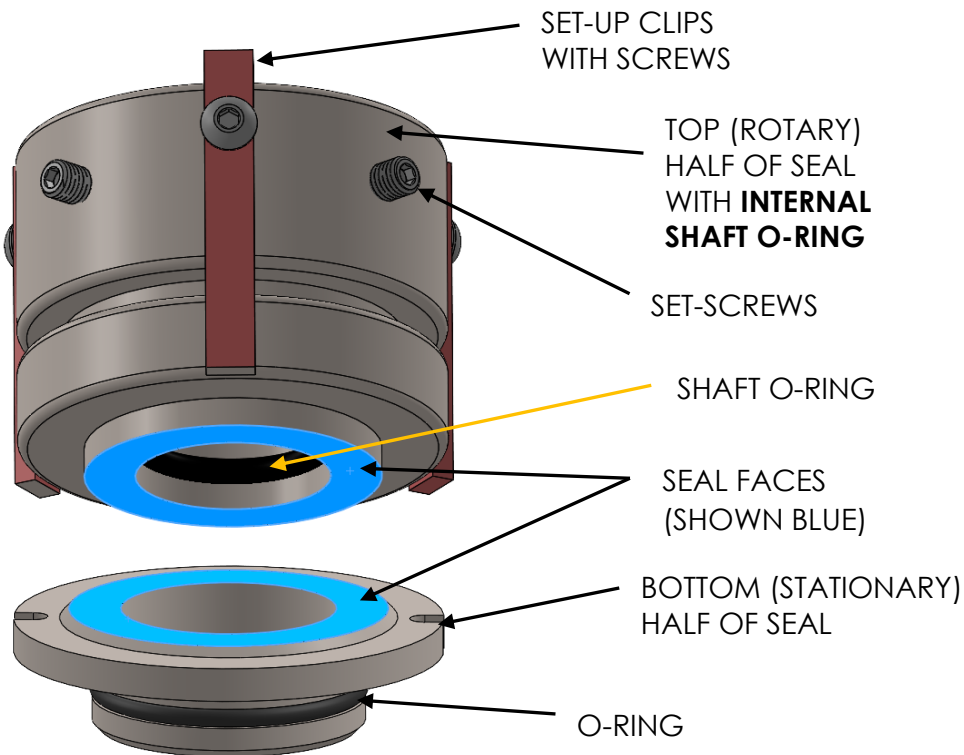
CAUTION: PINCH POINTS & SHARP EDGES MAY BE LOCATED IN THIS AREA

FSDS SEAL SHOWN SEPARATED (as received)

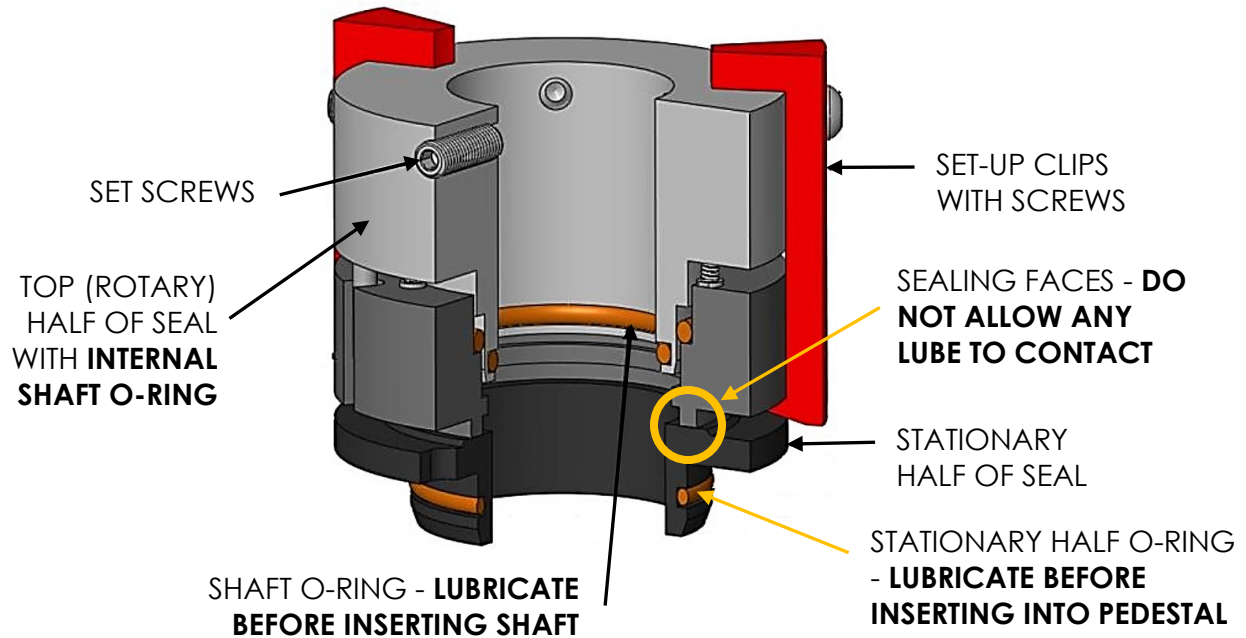

CUTAWAY OF FSDS SEAL
 (O-RINGS SHOWN ORANGE FOR VISIBILITY)

Important Warnings:

- **Make sure shaft is deburred & clean before installation**
- **Use clean gloves when installing seal**
- **Clean seal faces with isopropyl alcohol wipe or isopropyl on a clean lint-free cloth**

Install Bottom (Stationary) Half of Seal

Apply process-compatible lubricant on the external O-ring located in the bottom half of the seal. Align the roll pins installed in pedestal with slots in the bottom half of the seal when pressing seal half into pedestal bore. **WITH A CLEAN GLOVE HANDS - PUT PRESSURE ON INSIDE FACE (SHOWN IN BLUE) OF STATIONARY HALF OF SEAL DURING INSTALLATION.** The piloted design ensures that the seal is already aligned with the mixer shaft.



CAUTION: PRESSURE ON OUTSIDE FACES MAY CAUSE THE SEAL HALF TO FRACTURE.

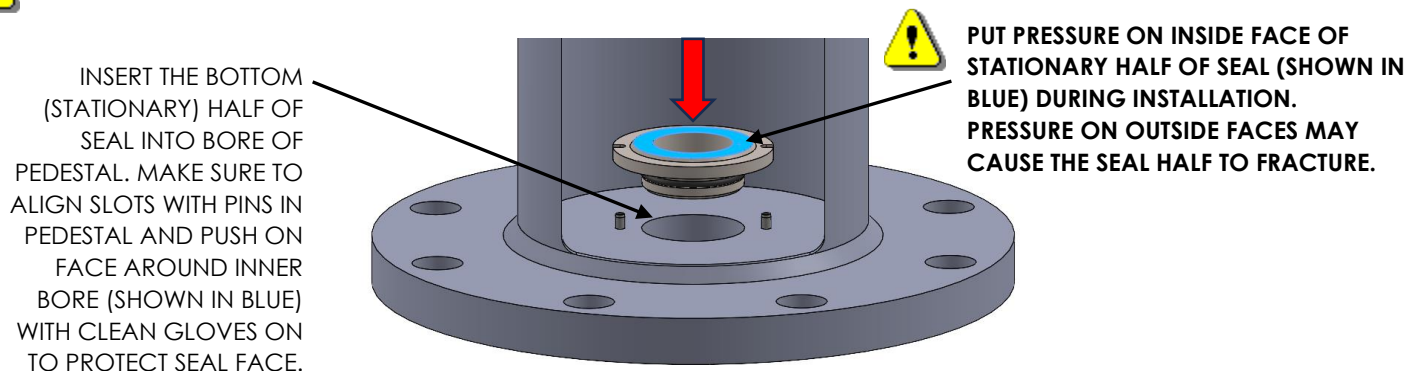

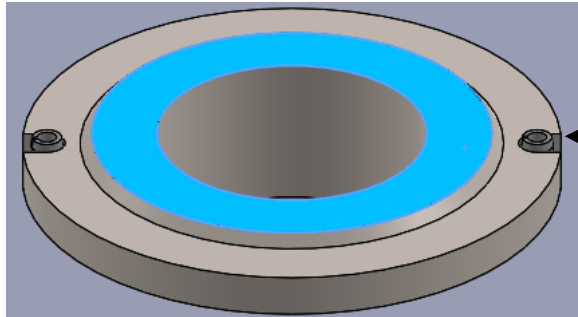

ENSURE THAT STATIONARY FACE IS FULLY SEATED INTO BORE. WIPE OFF SEAL FACE WITH AN ISOPROPYL WIPE OR CLEAN LINT FREE CLOTH IF NEEDED.

Float the Top (Rotating) Half Seal

Basic Seal Installation Process

- ✓ Insert Bottom (Stationary) Half of Seal (*Previously Completed*)
- Float the Seal
- Install the Shaft
- Mount the Seal
- Tighten Set Screws onto Shaft
- Remove Set-up Clips

Handle the seal with care to prevent damage to the fragile sealing faces of the seal.

Back out the set screws on the rotary half of the seal so they are clear of the bore. Use of a process-compatible lubricant on the O-ring located within the bore of the seal will help the shaft pass through the O-ring. Do not apply or allow any grease to contact the carbon or silicon carbide mating faces of the seal. To Float the Seal, position the seal in the pedestal and orient with the mounting face toward the base of the pedestal. Insert the shaft through the pedestal then into the mechanical seal bore. Slide the shaft through the bore of the seal.

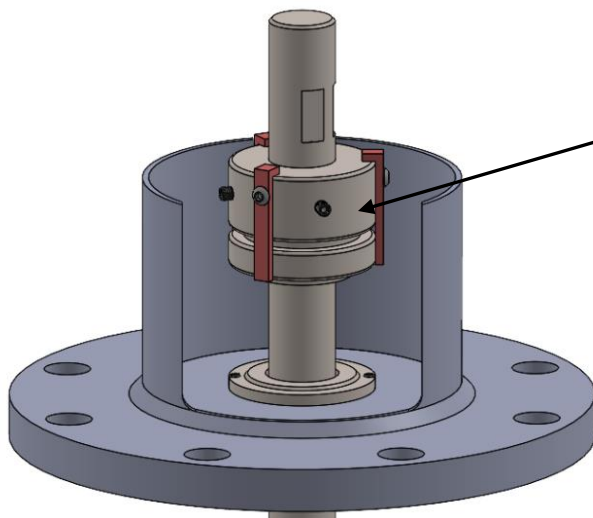

TRY TO AVOID CONTACT WITH THE SEAL FACES DURING THIS PROCESS. INSERT SHAFT THROUGH BOTTOM - STATIONARY HALF & TOP - ROTARY HALF OF SEAL AS SHOWN. (TOP OF PEDESTAL NOT SHOWN FOR CLARITY)

CHECK FOR SHARP EDGES OR BURRS ON SHAFT BEFORE INSERTING INTO SEAL. DEBURR AS NECESSARY TO PREVENT DAMAGE TO O-RINGS.

Seal installation will resume after the shaft is properly installed.

Install drive end of shaft to mixer drive. See appropriate shaft installation section for your mixer model.

Complete Seal Installation

Now that the shaft is properly located and securely affixed, complete the mechanical seal installation. Here is the basic process:

Basic Seal Installation Process

- ✓ Insert Bottom (Stationary) Half of Seal (*Previously Completed*)
- ✓ Float the Seal (*Previously Completed*)
- ✓ Install the Shaft (*Previously Completed*)
- Mount the Seal
- Tighten Set Screws onto Shaft
- Remove Set-up Clips



CAUTION: PINCH POINTS & SHARP EDGES MAY BE LOCATED IN THIS AREA

Mount the Seal

The installation clips that hold the seal together and set the spring tension should remain in place until the end of the installation process. **Make sure not to come in contact with seal faces during this process.** Push rotary seal half on shaft towards stationary half in pedestal. **Ensure that rotary and stationary seal faces are in contact.**

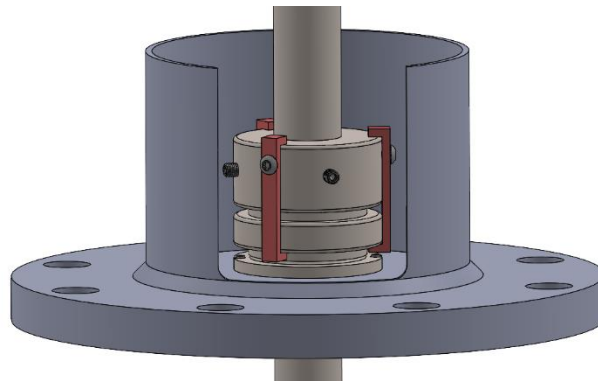

Tighten Set Screws onto Shaft

Once the seal halves are in place, use an alternating sequence to tighten and then torque the shaft set screws located on the rotating collar of the seal. The goal is to keep the shaft centered within the seal bore, rather than pushed completely to one side. Start by loosely snugging the set screws in the prescribed pattern, then tighten the set screws a little more, and a little more, repeating the same pattern multiple times. Finally, torque the set screws to the appropriate value in table on next page.

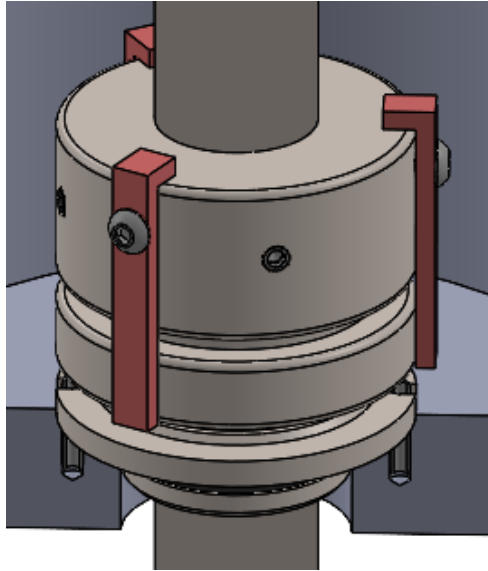

| HEX SIZE | SET SCREW THREAD SIZE | 304 TORQUE SPECIFICATION |
|----------|-----------------------|--------------------------|
| 1/8" | 1/4" | 72 in-lb |
| 5/32" | 5/16" | 147 in-lb |
| 3/16" | 3/8" | 22 FT-LB |

- ✓ Insert Bottom (Stationary) Half of Seal (*Previously Completed*)
- ✓ Float the Seal (*Previously Completed*)
- ✓ Install the Shaft (*Previously Completed*)
- ✓ Mount the Seal (*Previously Completed*)
- ✓ Tighten Set Screws onto Shaft (*Previously Completed*)
- Remove Set-up Clips

Remove Set-up Clips

A common mistake is failure to **REMOVE THE SET-UP CLIPS** at the end of the seal installation process. **FAILURE TO PERFORM THIS STEP WILL IMPACT PERFORMANCE AND CAUSE DAMAGE TO THE SEAL. REMOVE SET-UP CLIPS AND BE SURE TO SAVE THE SEAL'S SET-UP CLIPS.** They will be essential for future disassembly, shipment, rebuild, and reassembly of the mechanical seal.

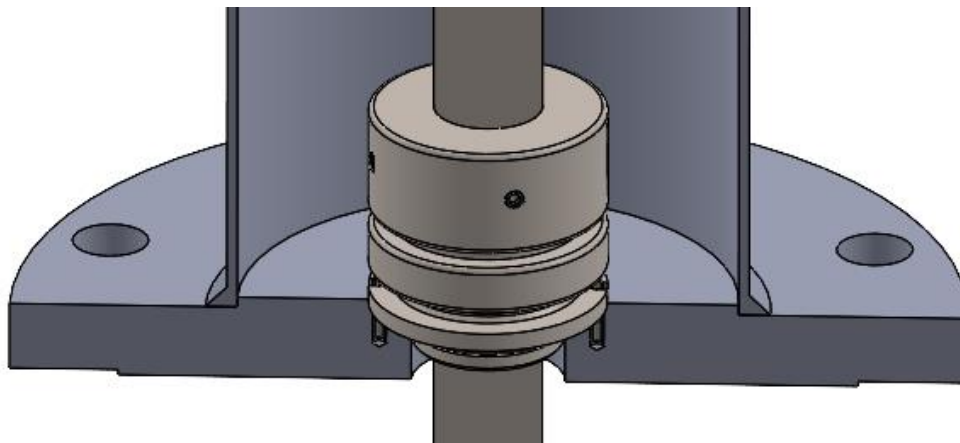

Removal of Seal



CAUTION:

IF YOUR MIXER HAS BEEN IN PROCESS WITH TOXIC OR HAZARDOUS PRODUCT, ENSURE THAT THE MIXER AND SEAL HAVE BEEN PROPERLY DECONTAMINATED AND CLEANED BEFORE ATTEMPTING ANY SEAL MAINTENANCE.

ENSURE THAT THE TANK IS AT ATMOSPHERIC PRESSURE BEFORE ATTEMPTING ANY SEAL MAINTENANCE.

Removal of seal is the reverse of installation.