

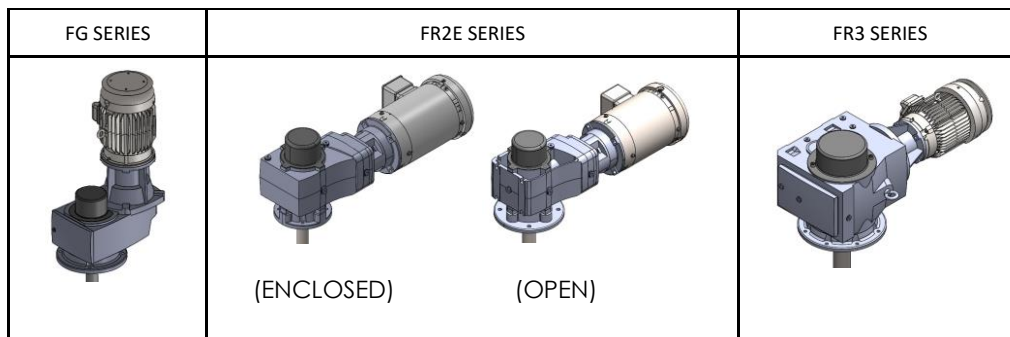

CAUTION:

- **ALWAYS SHUT OFF AND LOCK OUT POWER SOURCE AND DISCONNECT FROM POWER SOURCE BEFORE SERVICING MIXER. FAILURE TO FOLLOW THESE INSTRUCTIONS COULD RESULT IN DEATH, PERSONAL INJURY OR PROPERTY DAMAGE.**
- **PINCH POINTS & SHARP EDGES MAY BE LOCATED IN THIS AREA.**
- **HEAVY COMPONENTS – HANDLE PROPERLY.**

The following Fusion mixer models may use a shrink disc to secure the shaft to the Nord gearbox:



Shrink Disc Assembly Concept

The shrink disc uses outer clamping discs and a double tapered inner ring to provide radial contact pressure on the mixer shaft. As the locking screws are properly tightened, the inner ring applies pressure on the mixer shaft creating a high-capacity interference fit (see image below).

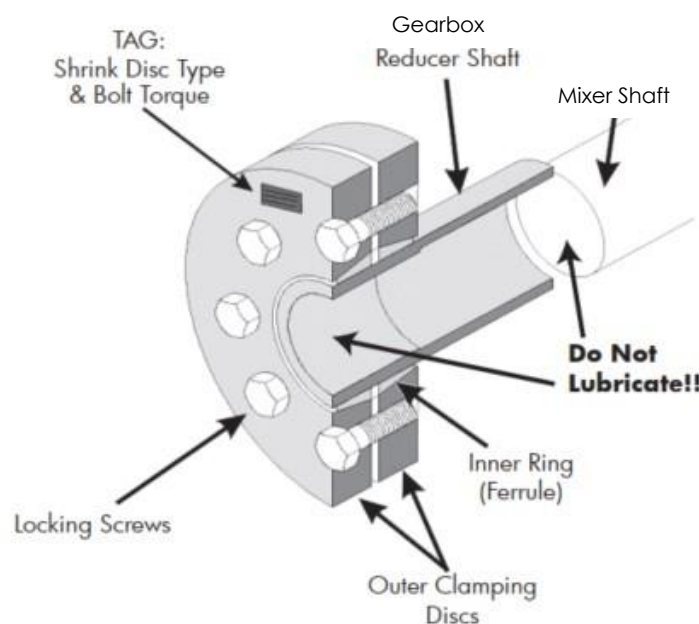

Shrink Disc Marked for Assembly Alignment

For mixers with shaft diameter 1.50" or smaller, the Shrink Disc system will be test run at Fusion Fluid Equipment to ensure shaft is running true. Once the optimum running position is determined at the Fusion factory, the gearbox hollow bore, shrink disc & shaft are marked with hammer peens & paint pen marks around 90 degrees apart (see image below). Make sure to align these marks when assembling the shaft to the gearbox using the Shrink Disc system.

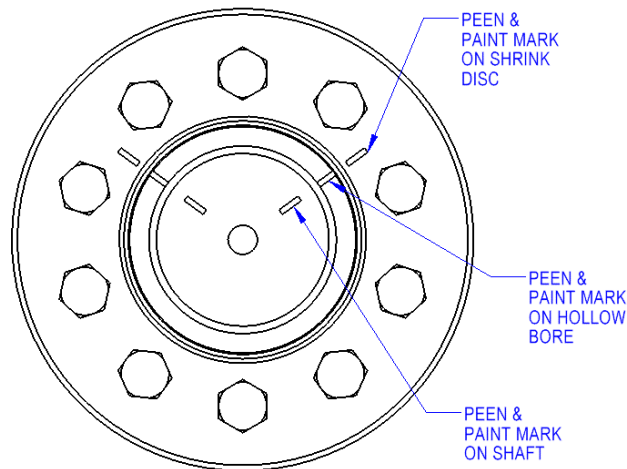

Shaft Installation with Shrink Disc

- 1) Remove the gearbox's shaft cover by removing the bolts that hold it down. Keep the shaft cover and bolts.

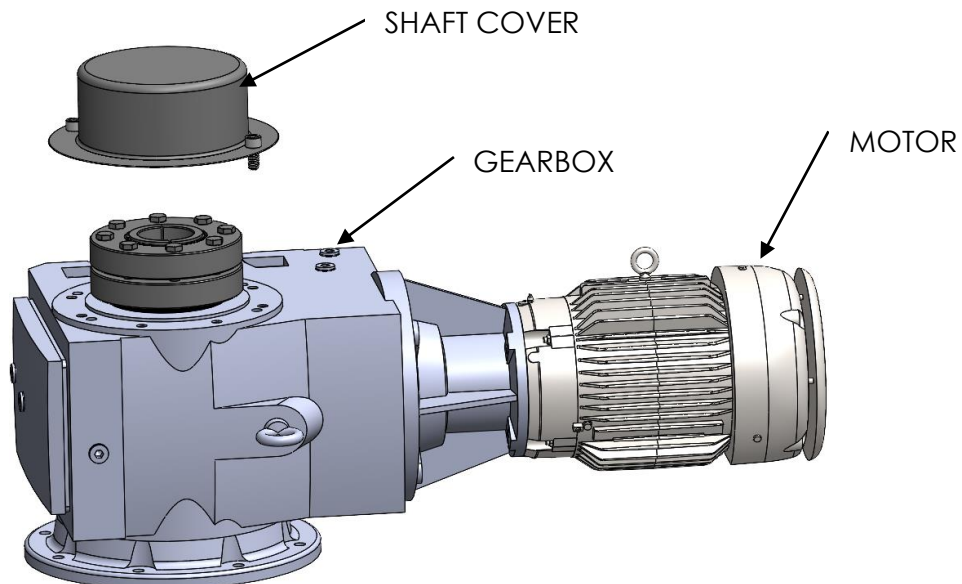

CAUTION:
 TIGHTENING
 SHRINK DISC
 WITHOUT A SHAFT
 IN THE BORE, WILL
 CAUSE DAMAGE
 TO THE GEARBOX.

- 2) Make sure shaft and gearbox hollow bore are free from any rust, corrosion, lubricants, nicks, burrs or foreign matter. If nicks or burrs are present, remove them using an abrasive material such as an emery cloth or Scotch-Brite pad. Clean shaft and hollow bore ID with acetone or a similar solvent.

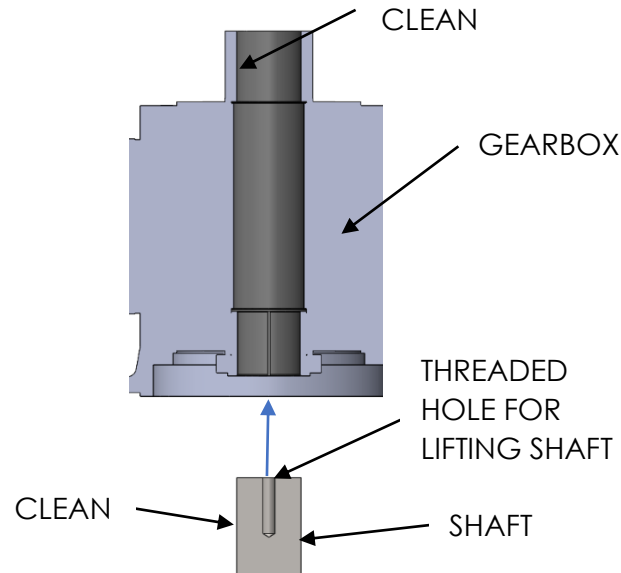

- 3) Verify all the bolts on the shrink disc are loose and slide the shrink disc onto the hollow bore OD.

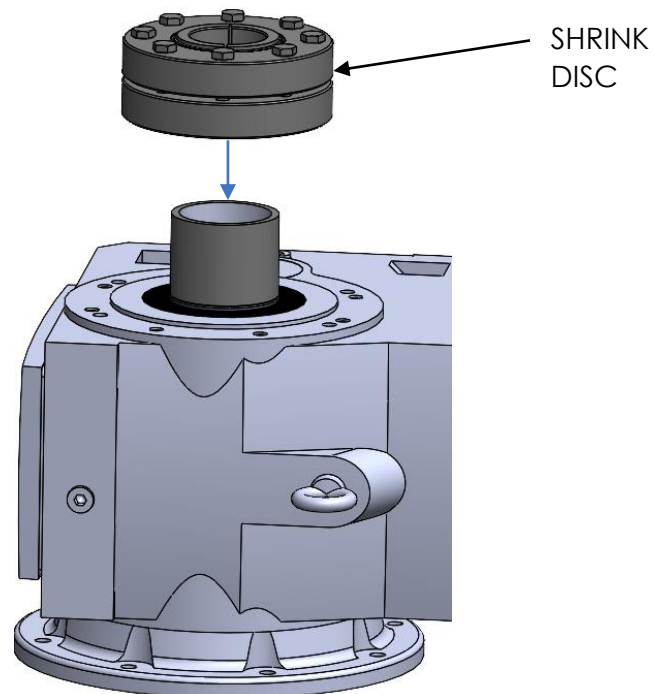

- 4) Insert the shaft into the gearbox hollow bore. Position the shaft so it's flush with the gearbox hollow bore or as indicated on the approval (or as manufactured) drawing. The shaft will typically have a threaded hole in the end which can be used for lifting shaft in position and holding until the shrink disc is installed. The mixer shaft can be "BLOCKED UP" in position if an eyebolt cannot be used. **Make sure to align peen & paint marks on the gearbox hollow bore, shrink disc & shaft if equipped as mentioned above.**

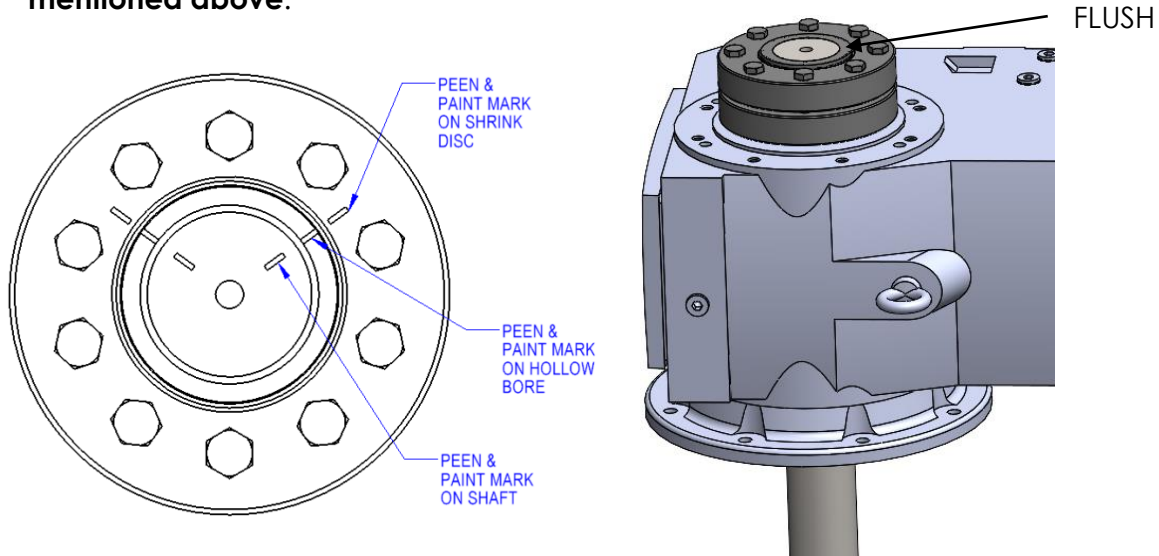

- 5) Verify there is clearance between the gearbox and the shrink disc. Hand tighten 3 or 4 equally spaced bolts. **MAKE SURE THE OUTER COLLARS OF THE SHRINK DISC ARE DRAWN TOGETHER IN A PARALLEL FASHION.** Then hand tighten the remaining bolts. **DO NOT TIGHTEN THE SHRINK DISC WITHOUT A SHAFT IN THE BORE OF THE GEARBOX, AS THIS WILL CAUSE DAMAGE TO THE GEARBOX.**

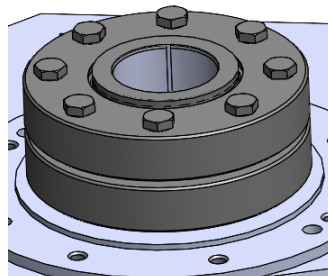
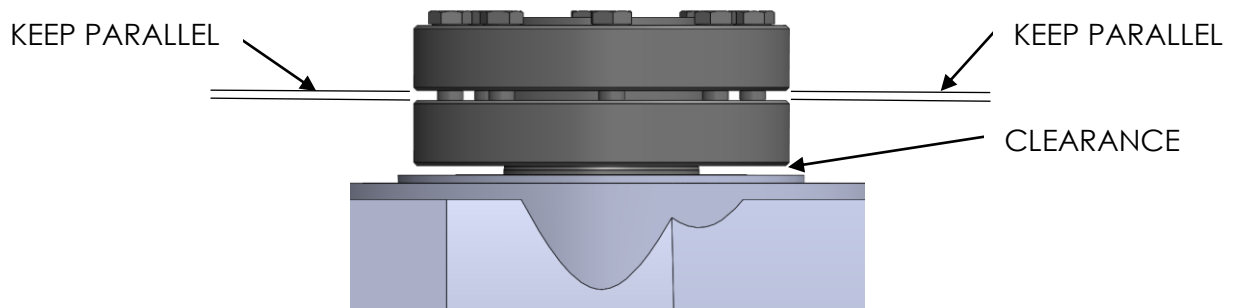

CAUTION: TIGHTENING SHRINK DISC WITHOUT A SHAFT IN THE BORE, WILL CAUSE DAMAGE TO THE GEARBOX.

- 6) Tighten the bolts in a circular pattern using 1/4 (90°) turns, even if some bolts initially require very low tightening torque to achieve 1/4 turns. **ENSURE THE SHRINK DISC IS TIGHTENING EVENLY AND PARALLEL.** Tighten the bolts to the appropriate “tightening torque” value in the table on next page.

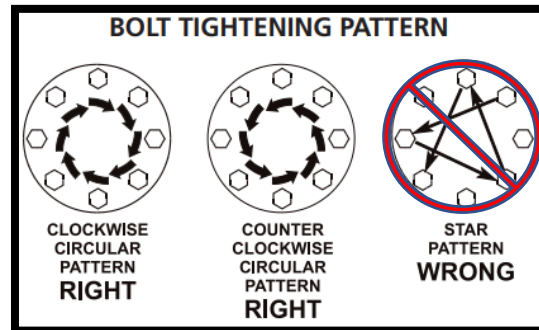

ENSURE THE SHRINK DISC IS TIGHTENING EVENLY AND PARALLEL

Screw Size	Wrench Size	Tightening Torque	4% Over Torque
M5	8	62 in-lb.	64 in-lb.
M6	10	106 in-lb.	110 in-lb.
M8	13	22 ft-lb.	23 ft-lb.
M10	17	44 ft-lb.	46 ft-lb.
M12	19	74 ft-lb.	77 ft-lb.
M16	24	184 ft-lb.	191 ft-lb.
M20	30	361 ft-lb.	375 ft-lb.
M24	36	620 ft-lb.	645 ft-lb.
M30	46	1254 ft-lb.	1304 ft-lb.

- 7) When the torque on the bolt is at the “tightening torque” value with less than 1/4 turn on the bolt, proceed to step 8.
- 8) Set the torque wrench to the appropriate value in the table, but use the “4% over torque” value in the table. Do one or two complete rotations using the same circular pattern technique.
- 9) Reset the torque wrench to the appropriate “tightening torque” value in the table. Confirm all of the bolts are tightened to the torque value using the circular pattern.
- 10) If an eyebolt or blocking was used to support shaft during shrink disc installation, this can now be removed.

11) Install the shaft cover and bolts back onto the gearbox.

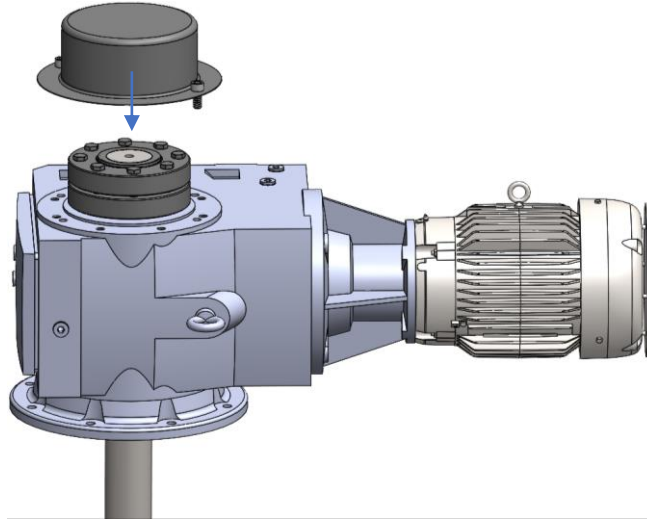

For additional Shaft Installation with Shrink Disc support go to our YouTube Channel - [FusionFluidEquipment](https://www.youtube.com/channel/UCFusionFluidEquipment)

Removal of Shrink Disc



DANGER:

MAKE SURE MIXER SHAFT IS SUPPORTED BEFORE THE LOOSENING ANY OF THE SHRINK DISC BOLTS. FAILURE TO DO SO COULD RESULT IN PERSONNEL INJURY, DEATH, DAMAGE TO MIXER SHAFT OR MIXING TANK.

- 1) Make sure the mixer shaft is supported in operating position before removing shrink disc. An eyebolt can be use in the threaded hole in the end of the shaft to hold the shaft in place while the shrink disc is removed. The mixer shaft can be “BLOCKED UP” in place if an eyebolt cannot be used.
- 2) Loosen the shrink disc locking screws in a circular pattern by using $\frac{1}{2}$ (180°) turns, until the shrink disc hub can be moved or until the shrink disc hub and reducer shaft will return to their original fits.



DANGER:

DO NOT COMPLETELY REMOVE THE LOCKING SCREWS BEFORE THE OUTER CLAMPING DISKS OF THE SHRINK DISC ARE DISENGAGED FROM THE INNER RING. A SUDDEN RELEASE OF THE OUTER COLLARS WILL CREATE HIGH SEPARATING FORCES AND COULD RESULT IN INJURY OR EVEN DEATH.

- 3) Loosen the outer collars of the shrink disc from the tapered inner ring. This may require tapping the bolts with a soft faced hammer or prying lightly between the outer collars.
- 4) Remove the mixer shaft from the gearbox.

Re-installation of Shrink Disc

It may be possible to re-use the shrink disc. However, the shrink disc should not be re-used if it becomes damaged during removal, or if excessively rusty or corroded.

- 1) Shrink discs must always be disassembled and thoroughly cleaned before re-using.
- 2) After cleaning the shrink disc, lubricate between the taper of the outer clamping disks and the outside of the inner ring using MOLYKOTE® G-Rapid Plus Paste (product of Dow Corning) or equivalent. In addition, grease screw threads and head contact area with multi-purpose grease.
- 3) The gearbox hollow bore should be thoroughly cleaned and check for damage before reinstalling mixer shaft.
- 4) Begin shrink disc assembly installation starting on page 2.