

This manual section covers "J" Style Nylon Coupling NEMA C-face installation.

Below are images of "J" Style Couplings which are used to couple the motor drive shaft to the gearbox spline shaft.

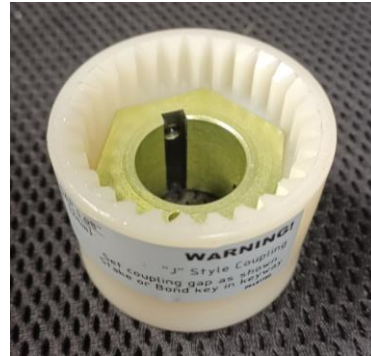

"J" Style Coupling 5/8" Bore



"J" Style Coupling 7/8" Bore

- Using a combination square, measure the distance from the face of the input adapter mounting flange to the face of the splined shaft and record that measurement as A in the equation on the following page.

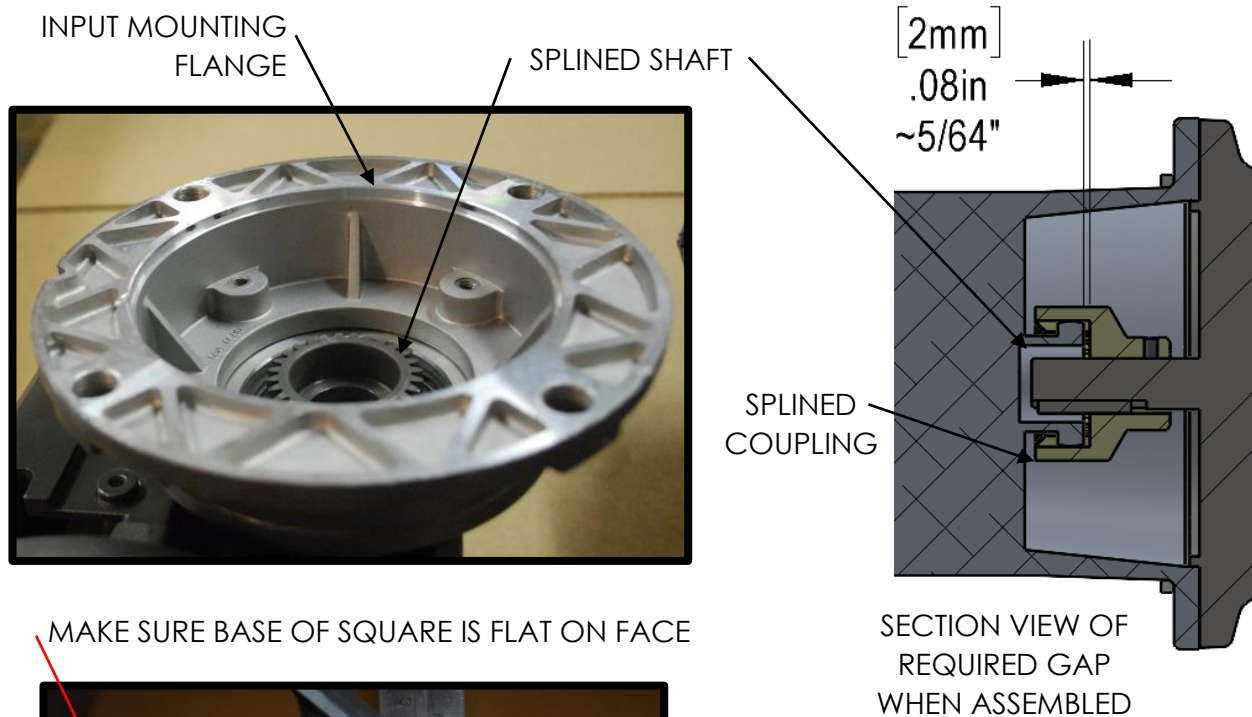

MAKE SURE BASE OF SQUARE IS FLAT ON FACE

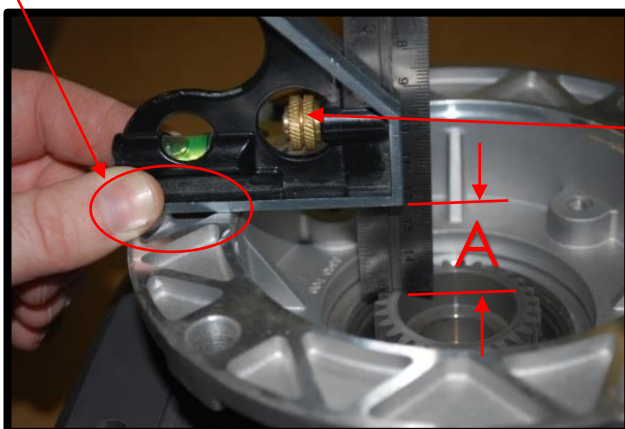

TIGHTEN SQUARE TO
KEEP MEASUREMENT

- 2) Measure the depth of coupling engagement zone of female splined coupling and record the measurement as B in the equation on the following page.

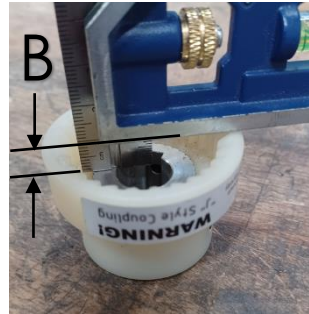
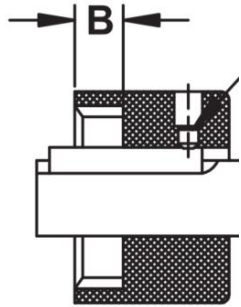

- 3) Add "A" + "B" and subtract 0.08" (2mm) ~5/64" from the distance. This needs to be done so that the coupling will not be axially preloaded after installation!

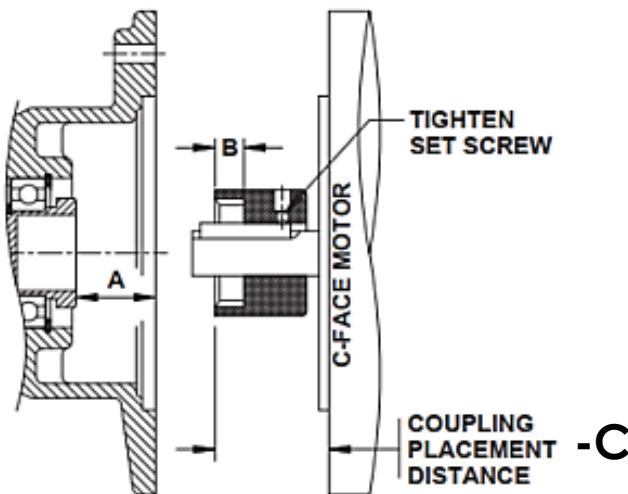

MEASURED DISTANCES		SUBTRACT DISTANCE		COUPLING PLACEMENT DISTANCE - C	
A	+	B	-	.08" (2mm)	=
_____	+	_____	-	~5/64"	= _____
			(minus)		

- 4) Use measurement "C" to locate the coupling from the face of the motor onto the shaft.

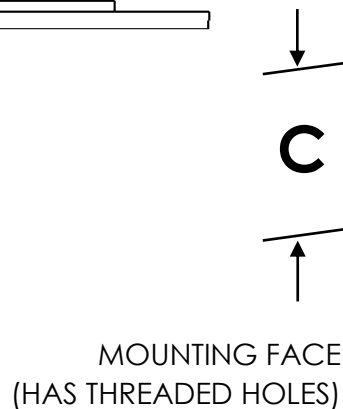
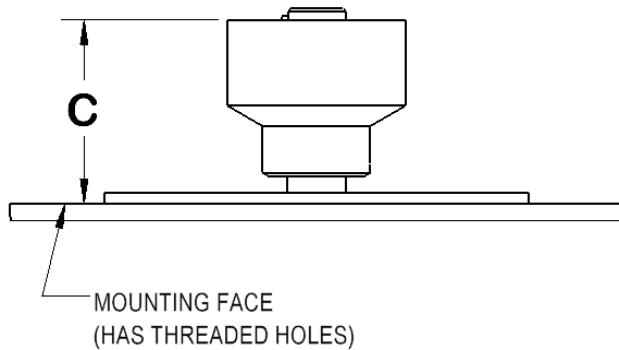

- 5) Once in place, tighten the set screws to lock the coupling in place. Tighten to a torque specification of 1.4 Nm (12.4 in-lbs.) It is recommended that the key is staked or bonded (Loctite) in place to prohibit the key from vibrating out.
- 6) Mount the motor onto the input adapter with appropriate bolts. Make sure that the coupling from the adapter and the motor engage securely. Use lock washers or Loctite to prohibit bolts from becoming loose from vibration.

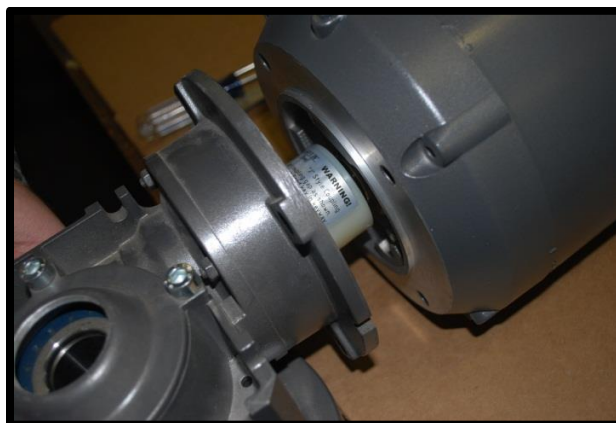

- One of the most common problems is a "noisy gearbox." This could be due to an improper gap causing the motor & gearbox shafts to be "axially loaded." We recommend disassembling and reassembling to ensure correct gap between spline adapter and coupling.

This manual section covers "M" Style Nylon Coupling NEMA C-face installation.

Below are images of the "M" Style Coupling components which are used to couple the motor drive shaft with key to the gearbox spline shaft.



Metal Hub



Nylon Sleeve with Spline

SECTION VIEW OF REQUIRED GAP (.31") WHEN ASSEMBLED

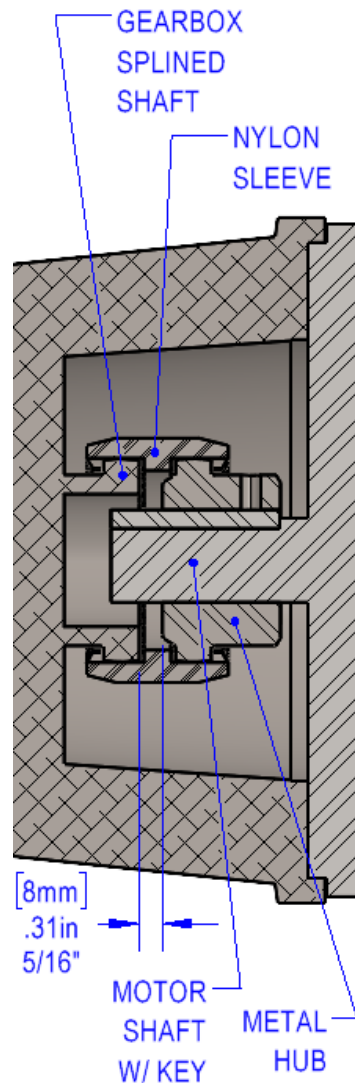

- Using a combination square, measure the distance from the face of the input adapter mounting flange to the face of the splined shaft and record that measurement in the equation below.

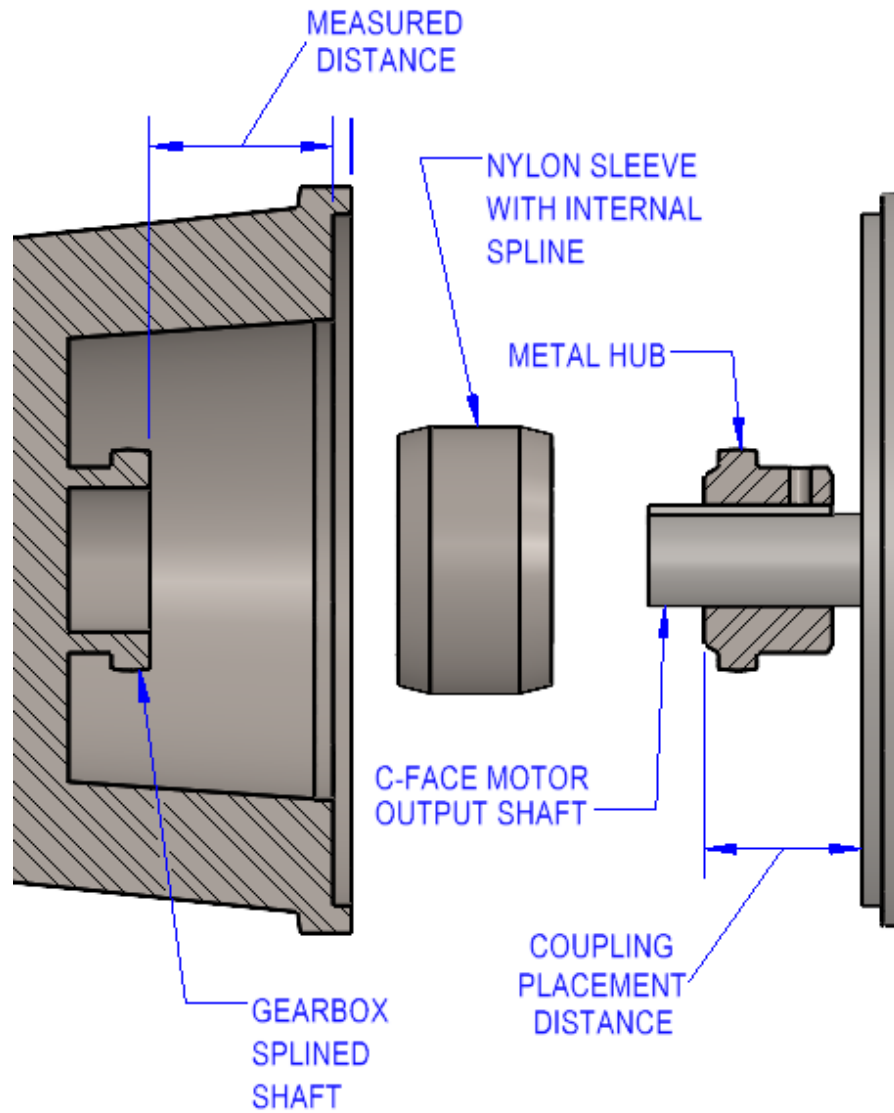

- Subtract 0.31" (8mm) 5/16" from the measured distance to get the coupling placement distance. This needs to be done so that the coupling assembly will not be axially preloaded after installation!

MEASURED DISTANCE	SUBTRACT DISTANCE	COUPLING PLACEMENT DISTANCE
_____	0.31" (8mm) =	_____
-	5/16"	
(minus)		

- 3) Use that measurement to locate the Metal Hub from the face of the motor onto the shaft.

- 4) Once in place, tighten the set screws to lock the Metal Hub in place. Tighten to the torque specification for the coupling size/screw size per the table below. It is recommended that the key is staked or bonded (Loctite) in place to prohibit the key from vibrating out.

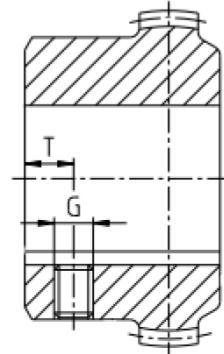

Size	14	19	24	28	32	38	42	48	65	80	100	125
Dimension G		M5				M8			M10		M12	M16
Dimension T		6				10			15 / 20 ¹⁾	20	30	40
Tightening torque T _A [Nm]		2				10			17		40	80

1) Length of hub 55 mm T = 15 mm, length of hub 70 mm T = 20 mm

- 5) Place Nylon Sleeve on either the Metal Hub mounted to the motor or the splined shaft on the gearbox depending on orientation of your assembly. Gravity will be holding the sleeve in place until the motor is attached to the gearbox. Mount the motor onto the input adapter with appropriate bolts. Make sure that the coupling from the adapter and the motor engage securely. Use lock washers or Loctite to prohibit bolts from becoming loose from vibration.