

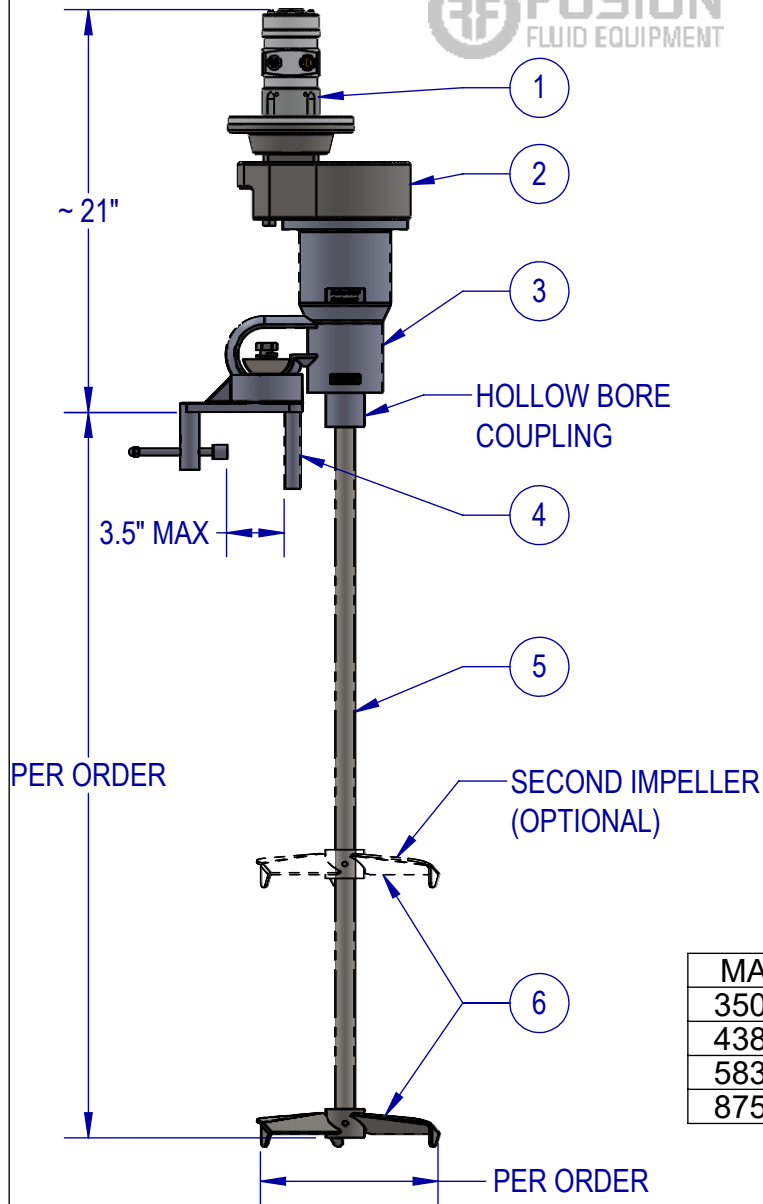

ITEM	QTY	DESCRIPTION
1	1	MOTOR - STAINLESS, PNEUMATIC, LUBE FREE, HP PER ORDER
2	1	GEARBOX - STAINLESS, 350 RPM, 5:1 REDUCTION, FDA SYNTHETIC OIL
3	1	BEARING HOUSING - STAINLESS, WITH HOLLOW BORE COUPLING
4	1	STAINLESS CLAMP MOUNT - BALL AND SOCKET TYPE
5	1	SHAFT - 316 STAINLESS STEEL SHAFT LENGTH AND DIAMETER PER ORDER
6	1+	IMPELLER - 316 STAINLESS STEEL PF3 HYDROFOIL IMPELLER, SIZE AND QTY PER ORDER

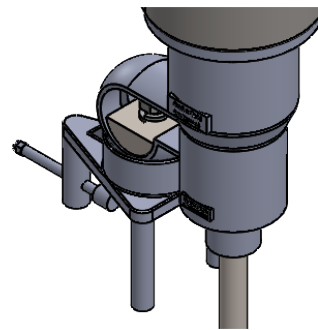

### CLAMP MOUNT DETAIL



### STANDARD FEATURES

- CAST STAINLESS HOUSING
- DUAL ABEC-RATED BEARINGS
- STAINLESS CLAMP
- STAINLESS ARBOR
- STAINLESS FASTENERS
- SEALED HOUSING (VITON LIP SEAL)

### AVAILABLE UPGRADES

- SPECIAL ALLOYS
- SANITARY FINISHES
- SHAFT COATINGS
- THREADED SANITARY COUPLINGS
- RIGID COUPLINGS
- VARIOUS IMPELLER SIZES, STYLES, AND QTY
- DIGITAL TACHOMETER
- PNEUMATIC CONTROLS
- FILTER/REGULATOR/LUBRICATOR (FRL)

MAX. SPEED TABLE	
350 RPM	STANDARD
438 RPM	OPTIONAL
583 RPM	OPTIONAL
875 RPM	OPTIONAL

AIR CONSUMPTION	
1 HP	55 CFM @ 100 PSI



EST WT. 86-102 LBS (DEPENDING ON HP AND OPTIONS)

### TYPICAL IMPELLER OPTIONS

PF3 HYDROFOIL	MARINE PROP	PBT - PITCH BLADE TURBINE	BIOPROP	PV3 HYDROFOIL	RUSHTON	FOLDING PROP

UNLESS OTHERWISE SPECIFIED:  
DIMENSIONS ARE IN INCHES.  
NO TOLERANCE IS IMPLIED.  
DO NOT SCALE DRAWING

NAME	DATE
DRAWN SB	7/20/22
CHECKED MB	8/22/22

PROPRIETARY AND CONFIDENTIAL

THE INFORMATION CONTAINED IN THIS DRAWING IS THE SOLE PROPERTY OF FUSION FLUID EQUIPMENT LLC. ANY REPRODUCTION IN PART OR AS A WHOLE WITHOUT THE WRITTEN PERMISSION OF FUSION FLUID EQUIPMENT LLC IS PROHIBITED.

WHILE FUSION FLUID EQUIPMENT LLC STRIVES TO MAINTAIN THE INTEGRITY OF A DESIGN AS APPROVED, FUSION FLUID EQUIPMENT LLC RETAINS THE RIGHT TO MAKE MODIFICATIONS DURING THE MANUFACTURING PROCESS TO IMPROVE FIT, FORM, AND FUNCTION OF THE DESIGN WITHOUT CUSTOMER NOTIFICATION OR CONSENT.

FUSION FLUID EQUIPMENT		
TITLE: FUSION PRO PGSA-C CLAMP MOUNT MIXER GEAR DRIVE AIR		
SIZE A	DWG. NO. SALES-PGSA-#C-#	REV B
SCALE: 1:12	WEIGHT:	SHEET 1 OF 1