



ITEM	QTY	DESCRIPTION
1	1	MOTOR - STAINLESS, WASHDOWN DUTY, HP PER ORDER
2	1	GEARBOX - STAINLESS, 350 RPM, 5:1 REDUCTION, FDA SYNTHETIC OIL
3	1	BEARING HOUSING - STAINLESS, WITH HOLLOW BORE COUPLING
4	1	ISOLATION MOUNTS - 8.5" X 8.5" STAINLESS PLATE
5	1	SHAFT - 316 STAINLESS STEEL SHAFT LENGTH AND DIAMETER PER ORDER
6	1+	IMPELLER - 316 STAINLESS STEEL PF3 HYDROFOIL IMPELLER, SIZE AND QTY PER ORDER

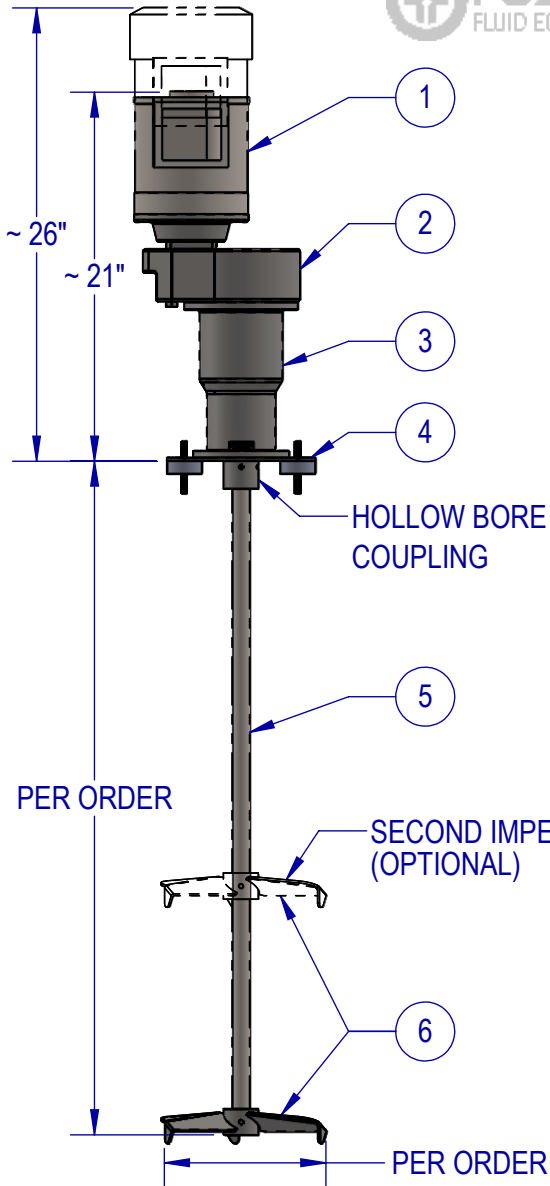
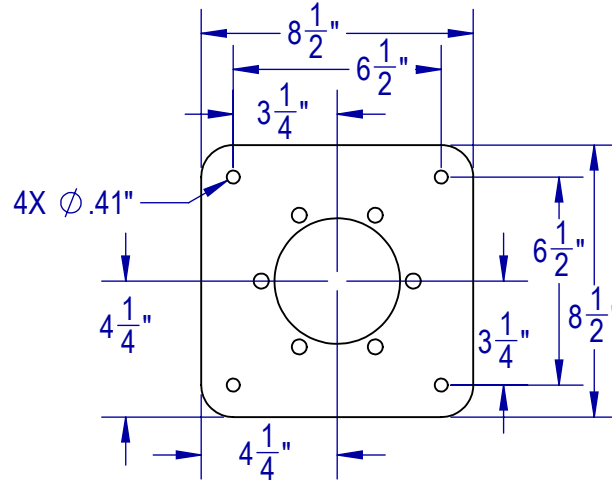
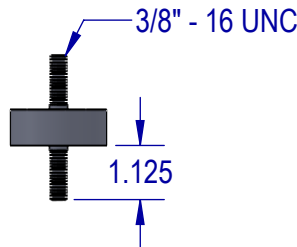

PLATE MOUNT DETAIL



ISOLATION MOUNT



STANDARD FEATURES

- CAST STAINLESS HOUSING
- DUAL ABEC-RATED BEARINGS
- STAINLESS PLATE MOUNT
- STAINLESS ARBOR
- STAINLESS FASTENERS
- SEALED HOUSING (VITON LIP SEAL)

AVAILABLE UPGRADES

- SPECIAL ALLOYS
- SANITARY FINISHES
- SHAFT COATINGS
- THREADED SANITARY COUPLINGS
- RIGID COUPLINGS
- VARIOUS IMPELLERS SIZES, STYLES, AND QTY
- DIGITAL TACHOMETER

SPEED TABLE	
350 RPM	STANDARD
438 RPM	OPTIONAL
583 RPM	OPTIONAL
875 RPM	OPTIONAL



EST WT. 75-125 LBS (DEPENDING ON HP AND OPTIONS)

TYPICAL IMPELLER OPTIONS

PF3 HYDROFOIL	MARINE PROP	PBT - PITCH BLADE TURBINE	BIOPROP	PV3 HYDROFOIL	RUSHTON	FOLDING PROP

UNLESS OTHERWISE SPECIFIED:
DIMENSIONS ARE IN INCHES.
NO TOLERANCES IMPLIED.
DO NOT SCALE DRAWING

NAME	DATE
DRAWN SB	7/21/22
CHECKED MB	8/22/22
PROPRIETARY AND CONFIDENTIAL	
THE INFORMATION CONTAINED IN THIS DRAWING IS THE SOLE PROPERTY OF FUSION FLUID EQUIPMENT LLC. ANY REPRODUCTION IN PART OR AS A WHOLE WITHOUT THE WRITTEN PERMISSION OF FUSION FLUID EQUIPMENT LLC IS PROHIBITED.	



TITLE: FUSION PRO PGS-P PLATE MOUNT MIXER GEAR DRIVE ELECTRIC		
SIZE	DWG. NO.	REV
A	SALES-PGS-#P-#	B
SCALE: 1:12	WEIGHT:	SHEET 1 OF 1