

ITEM	QTY	DESCRIPTION
1	1	MOTOR - STAINLESS, WASHDOWN DUTY, HP PER ORDER
2	1	GEARBOX - STAINLESS, 350 RPM, 5:1 REDUCTION, FDA SYNTHETIC OIL
3	1	BEARING HOUSING - STAINLESS, WITH HOLLOW BORE COUPLING
4	1	STAINLESS CLAMP MOUNT - BALL AND SOCKET TYPE
5	1	SHAFT - 316 STAINLESS STEEL SHAFT LENGTH AND DIAMETER PER ORDER
6	1+	IMPELLER - 316 STAINLESS STEEL PF3 HYDROFOIL IMPELLER, SIZE AND QTY PER ORDER

### CLAMP MOUNT DETAIL

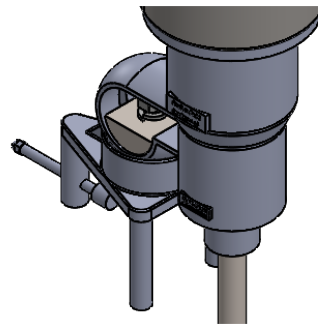

### STANDARD FEATURES

- CAST STAINLESS HOUSING
- DUAL ABEC-RATED BEARINGS
- STAINLESS CLAMP
- STAINLESS ARBOR
- STAINLESS FASTENERS
- SEALED HOUSING (VITON LIP SEAL)

### AVAILABLE UPGRADES

- SPECIAL ALLOYS
- SANITARY FINISHES
- SHAFT COATINGS
- THREADED SANITARY COUPLINGS
- RIGID COUPLINGS
- VARIOUS IMPELLERS SIZES, STYLES, AND QTY
- DIGITAL TACHOMETER

SPEED TABLE	
350 RPM	STANDARD
438 RPM	OPTIONAL
583 RPM	OPTIONAL
875 RPM	OPTIONAL



EST WT. 75-125 LBS (DEPENDING ON HP AND OPTIONS)

### TYPICAL IMPELLER OPTIONS

PF3 HYDROFOIL	MARINE PROP	PBT - PITCH BLADE TURBINE	BIOPROP	PV3 HYDROFOIL	RUSHTON	FOLDING PROP

UNLESS OTHERWISE SPECIFIED:  
DIMENSIONS ARE IN INCHES.  
NO TOLERANCES IMPLIED.  
DO NOT SCALE DRAWING

NAME	DATE
DRAWN SB	7/20/22
CHECKED MB	8/22/22

PROPRIETARY AND CONFIDENTIAL

THE INFORMATION CONTAINED IN THIS DRAWING IS THE SOLE PROPERTY OF FUSION FLUID EQUIPMENT LLC. ANY REPRODUCTION IN PART OR AS A WHOLE WITHOUT THE WRITTEN PERMISSION OF FUSION FLUID EQUIPMENT LLC IS PROHIBITED.

TITLE: FUSION PRO PGS-C CLAMP MOUNT MIXER GEAR DRIVE ELECTRIC

SIZE	DWG. NO.	REV
A	SALES-PGS-#C-#	B

SCALE: 1:12 WEIGHT: SHEET 1 OF 1