

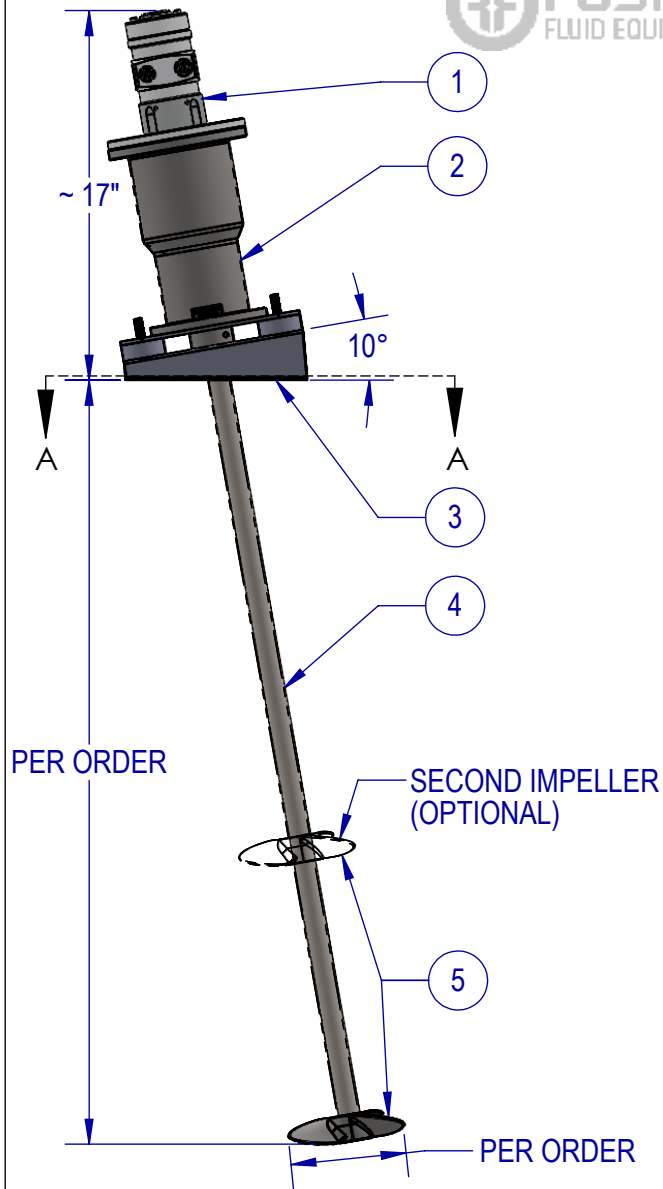

ITEM	QTY	DESCRIPTION
1	1	MOTOR - STAINLESS, PNEUMATIC, LUBE FREE, HP PER ORDER
2	1	BEARING HOUSING - STAINLESS, WITH HOLLOW BORE COUPLING
3	1	ANGLE RISER MOUNT ASSEMBLY W/ STAINLESS PLATE AND ISOLATION MOUNTS
4	1	SHAFT - 316 STAINLESS STEEL SHAFT LENGTH AND DIAMETER PER ORDER
5	1+	IMPELLER - 316 STAINLESS STEEL MARINE-TYPE IMPELLER, SIZE AND QTY PER ORDER



### ANGLE RISER DETAIL

SECTION A-A  
SCALE 1 : 7

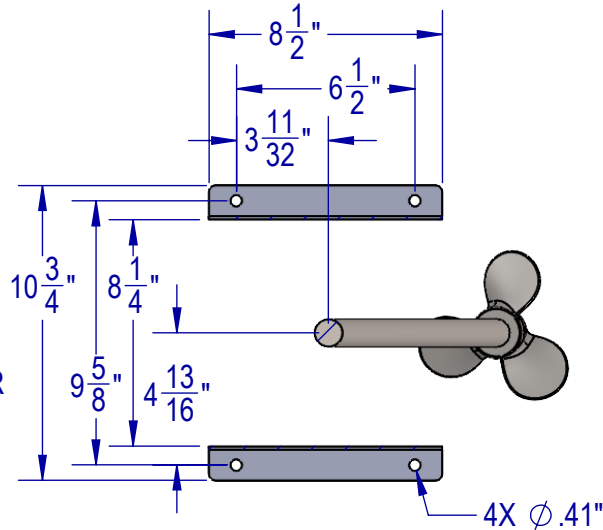

AIR CONSUMPTION	
1 HP	55 CFM @ 100 PSI

### STANDARD FEATURES

- CAST STAINLESS HOUSING
- DUAL ABEC-RATED BEARINGS
- STAINLESS PLATE MOUNT
- STAINLESS ANGLE RISERS
- STAINLESS ARBOR
- STAINLESS FASTENERS
- SEALED HOUSING (VITON LIP SEAL)

### AVAILABLE UPGRADES

- SPECIAL ALLOYS
- SANITARY FINISHES
- SHAFT COATINGS
- THREADED SANITARY COUPLINGS
- RIGID COUPLINGS
- VARIOUS IMPELLER SIZES, STYLES, AND QTY
- DIGITAL TACHOMETER
- PNEUMATIC CONTROLS
- FILTER/REGULATOR/ LUBRICATOR (FRL)



EST WT. 52-67 LBS (DEPENDING ON HP AND OPTIONS)

### TYPICAL IMPELLER OPTIONS

MARINE PROP	PBT - PITCH BLADE TURBINE	PF3 HYDROFOIL	BIOPROP	RUSHTON	COWLES (SAWTOOTH)	FOLDING PROP

UNLESS OTHERWISE SPECIFIED:  
DIMENSIONS ARE IN INCHES.  
NO TOLERANCE IS IMPLIED.  
DO NOT SCALE DRAWING

NAME	DATE
DRAWN SB	7/26/22
CHECKED MB	8/22/22

PROPRIETARY AND CONFIDENTIAL

THE INFORMATION CONTAINED IN THIS DRAWING IS THE SOLE PROPERTY OF FUSION FLUID EQUIPMENT LLC. ANY REPRODUCTION IN PART OR AS A WHOLE WITHOUT THE WRITTEN PERMISSION OF FUSION FLUID EQUIPMENT LLC IS PROHIBITED.

WHILE FUSION FLUID EQUIPMENT LLC STRIVES TO MAINTAIN THE INTEGRITY OF A DESIGN AS APPROVED, FUSION FLUID EQUIPMENT LLC RETAINS THE RIGHT TO MAKE MODIFICATIONS DURING THE MANUFACTURING PROCESS TO IMPROVE FIT, FORM, AND FUNCTION OF THE DESIGN WITHOUT CUSTOMER NOTIFICATION OR CONSENT.

FUSION FLUID EQUIPMENT		
TITLE: FUSION PRO PDSA-A ANGLE RISER MOUNT MIXER GEAR DRIVE AIR		
SIZE A	DWG. NO. SALES-PDSA-#A-#	REV B
SCALE: 1:9	WEIGHT:	SHEET 1 OF 1