

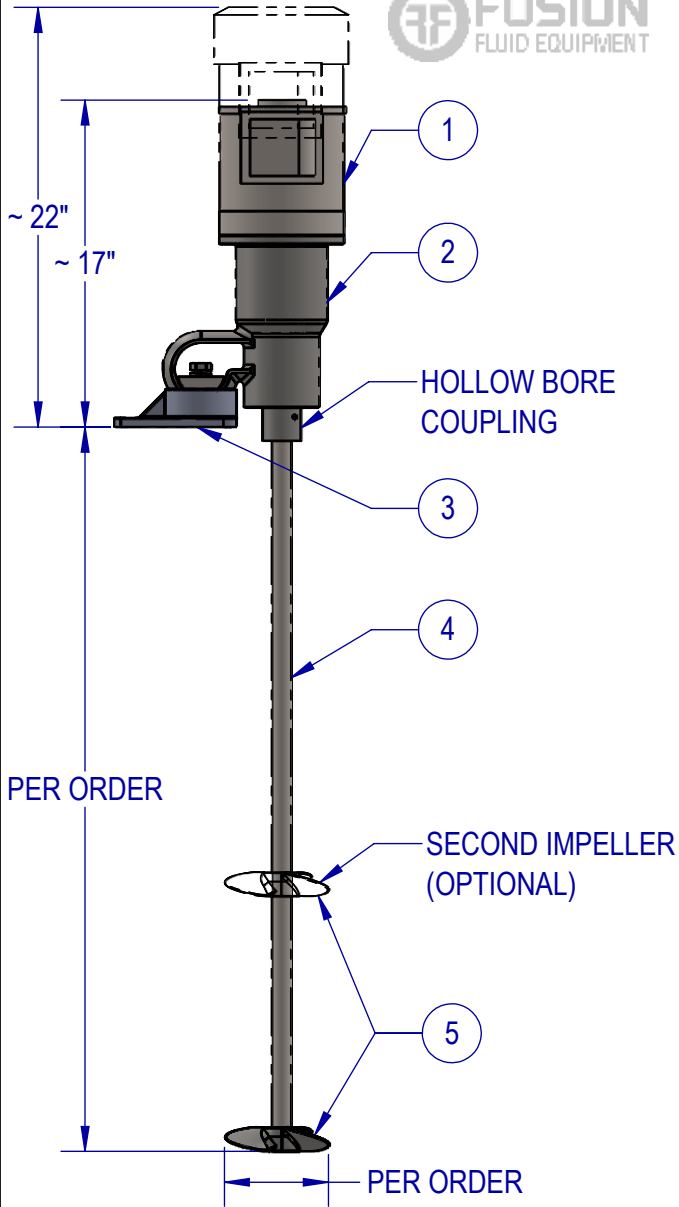

ITEM	QTY	DESCRIPTION
1	1	MOTOR - STAINLESS, WASHDOWN DUTY, HP PER ORDER
2	1	BEARING HOUSING - STAINLESS, WITH HOLLOW BORE COUPLING
3	1	STAINLESS CUP PLATE MOUNT - BALL AND SOCKET TYPE
4	1	SHAFT - 316 STAINLESS STEEL SHAFT LENGTH AND DIAMETER PER ORDER
5	1+	IMPELLER - 316 STAINLESS STEEL MARINE-TYPE IMPELLER, SIZE AND QTY PER ORDER

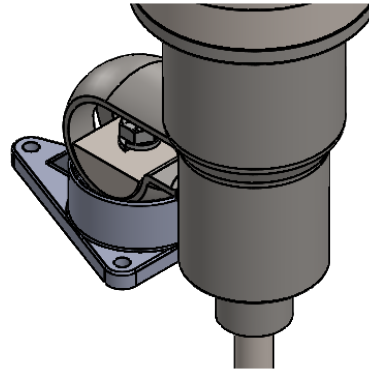

BALL & SOCKET DETAIL



CUP PLATE MOUNTING DETAIL

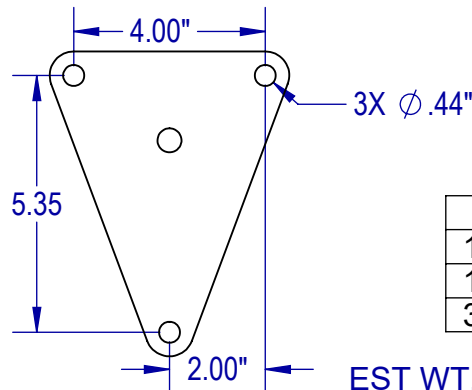

STANDARD FEATURES

- CAST STAINLESS HOUSING
- DUAL ABEC-RATED BEARINGS
- STAINLESS CUP PLATE MOUNT
- STAINLESS ARBOR
- STAINLESS FASTENERS
- SEALED HOUSING (VITON LIP SEAL)

AVAILABLE UPGRADES

- SPECIAL ALLOYS
- SANITARY FINISHES
- SHAFT COATINGS
- THREADED SANITARY COUPLINGS
- RIGID COUPLINGS
- VARIOUS IMPELLERS SIZES, STYLES, AND QTY
- DIGITAL TACHOMETER

SPEED TABLE	
1750 RPM	STANDARD
1150 RPM	OPTIONAL
3600 RPM	OPTIONAL



EST WT. 64-84 LBS (DEPENDING ON HP AND OPTIONS)

TYPICAL IMPELLER OPTIONS

MARINE PROP	PBT - PITCH BLADE TURBINE	PF3 HYDROFOIL	BIOPROP	RUSHTON	COWLES (SAWTOOTH)	FOLDING PROP

UNLESS OTHERWISE SPECIFIED:
DIMENSIONS ARE IN INCHES.
NO TOLERANCES IMPLIED.
DO NOT SCALE DRAWING

NAME	DATE
DRAWN SB	7/27/22
CHECKED MB	8/22/22

PROPRIETARY AND CONFIDENTIAL

THE INFORMATION CONTAINED IN THIS DRAWING IS THE SOLE PROPERTY OF FUSION FLUID EQUIPMENT LLC. ANY REPRODUCTION IN PART OR AS A WHOLE WITHOUT THE WRITTEN PERMISSION OF FUSION FLUID EQUIPMENT LLC IS PROHIBITED.



TITLE: FUSION PRO PDS-U CUP PLATE MOUNT MIXER DIRECT DRIVE ELECTRIC		
SIZE DWG. NO.	REV	
A SALES-PDS-#U-#	B	
SCALE: 1:10	WEIGHT:	SHEET 1 OF 1