

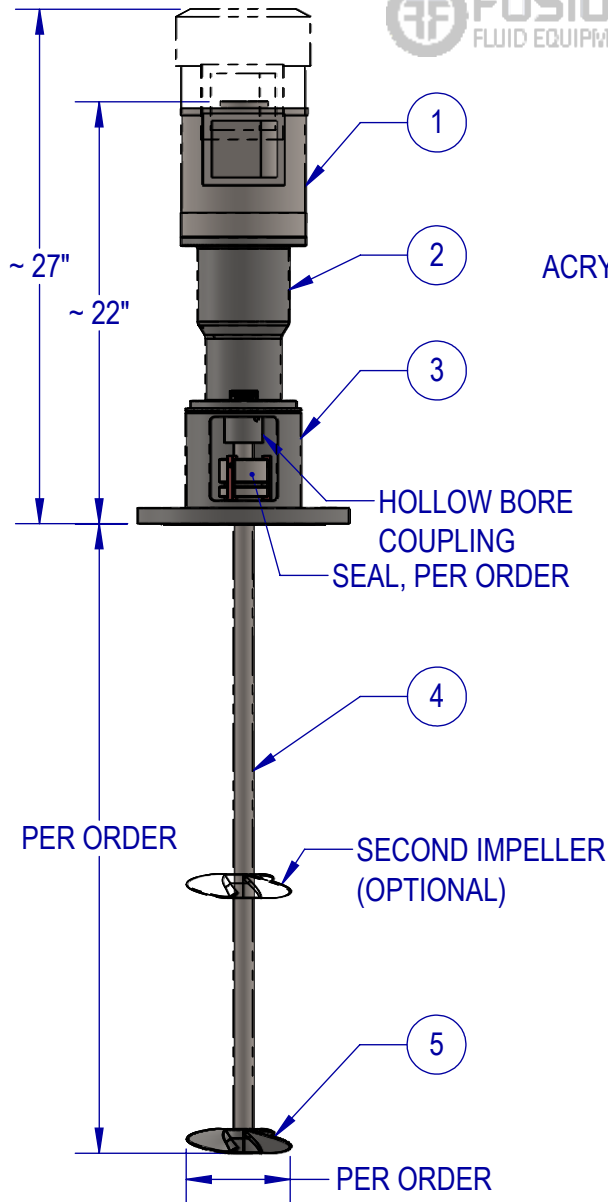

ITEM	QTY	DESCRIPTION
1	1	MOTOR - STAINLESS, WASHDOWN DUTY, HP PER ORDER
2	1	BEARING HOUSING - STAINLESS, WITH HOLLOW BORE COUPLING
3	1	PEDESTAL - MOUNTING FLANGE AND SEAL GLAND PER ORDER
4	1	SHAFT - 316 STAINLESS STEEL SHAFT LENGTH AND DIAMETER PER ORDER
5	1+	IMPELLER - 316 STAINLESS STEEL MARINE-TYPE IMPELLER, SIZE AND QTY PER ORDER



ACRYLIC GUARD PROVIDED (NOT SHOWN)

SHOWN WITH MECHANICAL SEAL

OPTIONAL TRICLAMP MOUNT

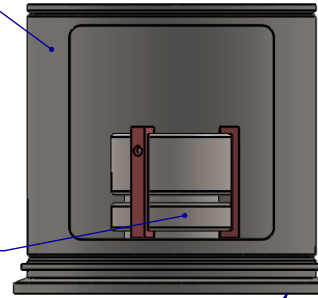

SPEED TABLE	
1750 RPM	STANDARD
1150 RPM	OPTIONAL
3600 RPM	OPTIONAL

STANDARD FEATURES

- CAST STAINLESS HOUSING
- DUAL ABEC-RATED BEARINGS
- STAINLESS MOUNTING FLANGE
- STAINLESS ARBOR
- STAINLESS FASTENERS
- ANSI CLASS 150# FLANGE
- SEALED HOUSING (VITON LIP SEAL)

AVAILABLE UPGRADES

- SPECIAL ALLOYS
- SANITARY FINISHES
- SHAFT COATINGS
- THREADED SANITARY COUPLINGS
- RIGID COUPLINGS
- VARIOUS IMPELLERS SIZES, STYLES, AND QTY
- DIGITAL TACHOMETER
- TRICLAMP MOUNT



SEAL OPTIONS	
LIP SEAL	SINGLE, DOUBLE, VITON, FDA RULON, & MORE
STUFFING BOX	LOW PRESSURE (15 PSI) OR HIGH PRESSURE (150 PSI)
MECHANICAL SEAL	FLOWSERVE, CHESTERTON, ROPLAN, & MORE

EST WT. 86-107 LBS (DEPENDING ON HP AND OPTIONS)

TYPICAL IMPELLER OPTIONS

MARINE PROP	PBT - PITCH BLADE TURBINE	PF3 HYDROFOIL	BIOPROP	RUSHTON	COWLES (SAWTOOTH)	FOLDING PROP

UNLESS OTHERWISE SPECIFIED:
DIMENSIONS ARE IN INCHES.
NO TOLERANCES IMPLIED.
DO NOT SCALE DRAWING

NAME	DATE
DRAWN SB	7/26/22
CHECKED MB	8/22/22

PROPRIETARY AND CONFIDENTIAL

THE INFORMATION CONTAINED IN THIS DRAWING IS THE SOLE PROPERTY OF FUSION FLUID EQUIPMENT LLC. ANY REPRODUCTION IN PART OR AS A WHOLE WITHOUT THE WRITTEN PERMISSION OF FUSION FLUID EQUIPMENT LLC IS PROHIBITED.



TITLE:	FUSION PRO PDS-F CLOSED TANK MIXER DIRECT DRIVE ELECTRIC		
SIZE	DWG. NO.	REV	
A	SALES-PDS-#-#	B	
SCALE: 1:10	WEIGHT:	SHEET 1 OF 1	