

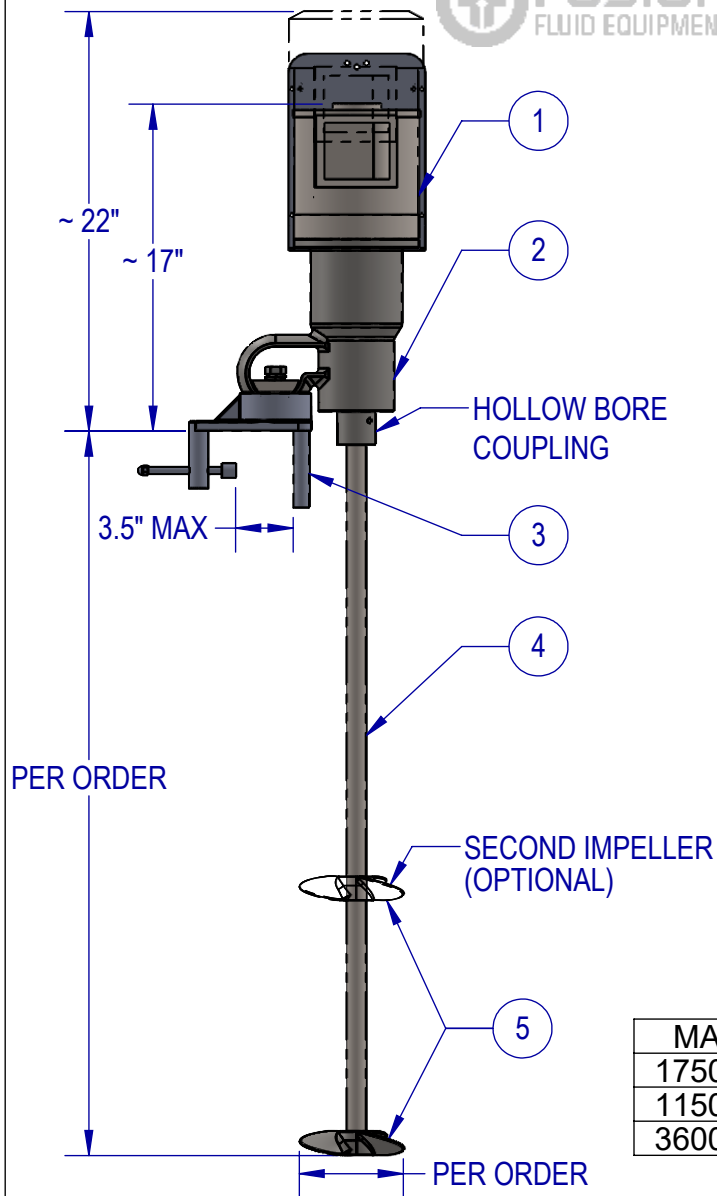

ITEM	QTY	DESCRIPTION
1	1	MOTOR - STAINLESS, WASHDOWN DUTY, HP PER ORDER
2	1	BEARING HOUSING - STAINLESS, WITH HOLLOW BORE COUPLING
3	1	STAINLESS CLAMP MOUNT - BALL AND SOCKET TYPE
4	1	SHAFT - 316 STAINLESS STEEL SHAFT LENGTH AND DIAMETER PER ORDER
5	1+	IMPELLER - 316 STAINLESS STEEL MARINE-TYPE IMPELLER, SIZE AND QTY PER ORDER

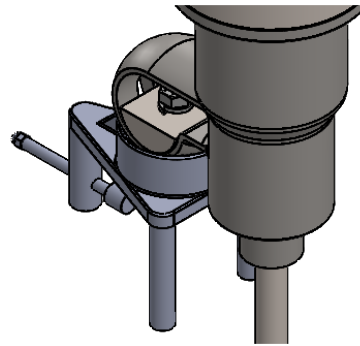

CLAMP MOUNT DETAIL



STANDARD FEATURES

- CAST STAINLESS HOUSING
- DUAL ABEC-RATED BEARINGS
- STAINLESS CLAMP
- STAINLESS ARBOR
- STAINLESS FASTENERS
- SEALED HOUSING (VITON LIP SEAL)
- DIGITAL SPEED CONTROL (VFD)
- VFD IS NEMA 4X OUTDOOR RATED

AVAILABLE UPGRADES

- SPECIAL ALLOYS
- SANITARY FINISHES
- SHAFT COATINGS
- THREADED SANITARY COUPLINGS
- RIGID COUPLINGS
- VARIOUS IMPELLER SIZES, STYLES, AND QTY
- DIGITAL TACHOMETER

VFD MOUNT DETAIL

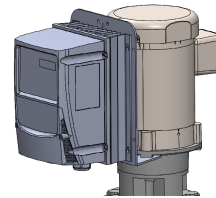

MAX. SPEED TABLE	
1750 RPM	STANDARD
1150 RPM	OPTIONAL
3600 RPM	OPTIONAL

EST WT: 100-125 LBS (DEPENDING ON HP AND OPTIONS)

TYPICAL IMPELLER OPTIONS

MARINE PROP	PBT - PITCH BLADE TURBINE	PF3 HYDROFOIL	BIOPROP	RUSHTON	COWLES (SAWTOOTH)	FOLDING PROP

UNLESS OTHERWISE SPECIFIED:
DIMENSIONS ARE IN INCHES.
NO TOLERANCE IS IMPLIED.
DO NOT SCALE DRAWING

	NAME	DATE
DRAWN	SB	7/26/22
CHECKED	MB	8/22/22

PROPRIETARY AND CONFIDENTIAL

THE INFORMATION CONTAINED IN THIS DRAWING IS THE SOLE PROPERTY OF FUSION FLUID EQUIPMENT LLC. ANY REPRODUCTION IN PART OR AS A WHOLE WITHOUT THE WRITTEN PERMISSION OF FUSION FLUID EQUIPMENT LLC IS PROHIBITED.

WHILE FUSION FLUID EQUIPMENT LLC STRIVES TO MAINTAIN THE INTEGRITY OF A DESIGN AS APPROVED, FUSION FLUID EQUIPMENT LLC RETAINS THE RIGHT TO MAKE MODIFICATIONS DURING THE MANUFACTURING PROCESS TO IMPROVE FIT, FORM, AND FUNCTION OF THE DESIGN WITHOUT CUSTOMER NOTIFICATION OR CONSENT.



FUSION FLUID EQUIPMENT		
TITLE: FUSION PRO PDS-C CLAMP MOUNT MIXER DIRECT DRIVE ELECTRIC WITH VFD		
SIZE A	DWG. NO. SALES-PDS-#C-#-V#	REV B
SCALE: 1:10	WEIGHT:	SHEET 1 OF 1