

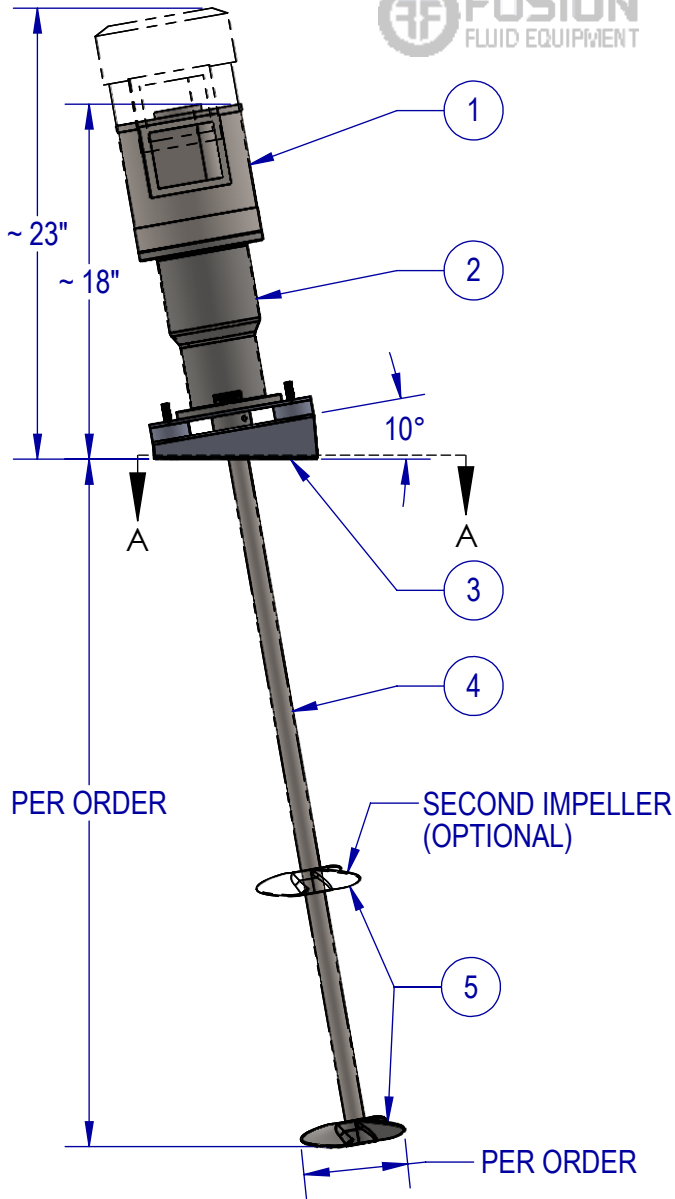

ITEM	QTY	DESCRIPTION
1	1	MOTOR - STAINLESS, WASHDOWN DUTY, HP PER ORDER
2	1	BEARING HOUSING - STAINLESS, WITH HOLLOW BORE COUPLING
3	1	ANGLE RISER MOUNT ASSEMBLY W/ STAINLESS PLATE AND ISOLATION MOUNTS
4	1	SHAFT - 316 STAINLESS STEEL SHAFT LENGTH AND DIAMETER PER ORDER
5	1+	IMPELLER - 316 STAINLESS STEEL MARINE-TYPE IMPELLER, SIZE AND QTY PER ORDER



### ANGLE RISER DETAIL

SECTION A-A  
SCALE 1 : 7

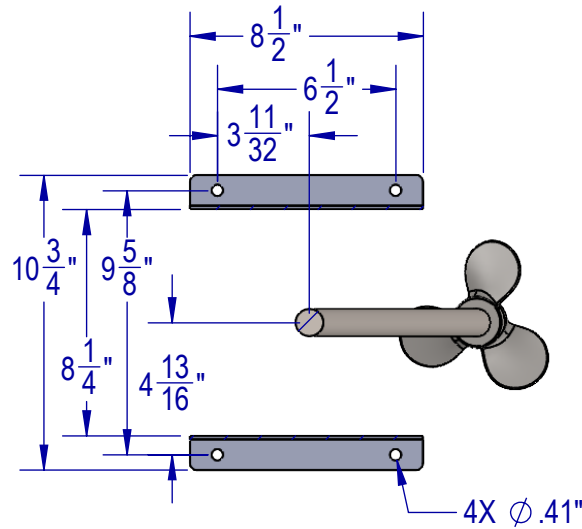

SPEED TABLE	
1750 RPM	STANDARD
1150 RPM	OPTIONAL
3600 RPM	OPTIONAL

### STANDARD FEATURES

- CAST STAINLESS HOUSING
- DUAL ABEC-RATED BEARINGS
- STAINLESS PLATE MOUNT
- STAINLESS ANGLE RISERS
- STAINLESS ARBOR
- STAINLESS FASTENERS
- SEALED HOUSING (VITON LIP SEAL)

### AVAILABLE UPGRADES

- SPECIAL ALLOYS
- SANITARY FINISHES
- SHAFT COATINGS
- THREADED SANITARY COUPLINGS
- RIGID COUPLINGS
- VARIOUS IMPELLERS SIZES, STYLES, AND QTY
- DIGITAL TACHOMETER



EST WT. 64-84 LBS (DEPENDING ON HP AND OPTIONS)

#### TYPICAL IMPELLER OPTIONS

MARINE PROP	PBT - PITCH BLADE TURBINE	PF3 HYDROFOIL	BIOPROP	RUSHTON	COWLES (SAWTOOTH)	FOLDING PROP

UNLESS OTHERWISE SPECIFIED:  
DIMENSIONS ARE IN INCHES.  
NO TOLERANCES IMPLIED.  
DO NOT SCALE DRAWING

NAME	DATE
DRAWN SB	7/26/22
CHECKED MB	8/22/22
PROPRIETARY AND CONFIDENTIAL	

THE INFORMATION CONTAINED IN THIS DRAWING IS THE SOLE PROPERTY OF FUSION FLUID EQUIPMENT LLC. ANY REPRODUCTION IN PART OR AS A WHOLE WITHOUT THE WRITTEN PERMISSION OF FUSION FLUID EQUIPMENT LLC IS PROHIBITED.



TITLE: FUSION PRO PDS-A ANGLE RISER MOUNT MIXER DIRECT DRIVE ELECTRIC		
SIZE	DWG. NO.	REV
A	SALES-PDS-#A-#	B
SCALE: 1:10	WEIGHT:	SHEET 1 OF 1