

ITEM	QTY	DESCRIPTION
1	1	MOTOR - CAST IRON, PNEUMATIC, LUBE REQUIRED, HP PER ORDER, PAINTED FINISH
2	1	BEARING HOUSING - ALUMINUM, WITH HOLLOW BORE COUPLING, PAINTED FINISH
3	1	PEDESTAL - MOUNTING FLANGE AND SEAL GLAND PER ORDER
4	1	SHAFT - 316 STAINLESS STEEL SHAFT LENGTH AND DIAMETER PER ORDER
5	1+	IMPELLER - 316 STAINLESS STEEL MARINE-TYPE IMPELLER, SIZE AND QTY PER ORDER

ACRYLIC GUARD PROVIDED (NOT SHOWN)

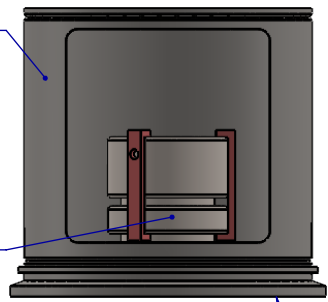

SHOWN WITH MECHANICAL SEAL

OPTIONAL TRICLAMP MOUNT

AIR CONSUMPTION @ 1800 RPM	
1 HP	40 CFM @ 80 PSI
2 HP	60 CFM @ 70 PSI
3 HP	90 CFM @ 70 PSI



STANDARD FEATURES

- CAST ALUMINUM HOUSING
- DUAL ABEC-RATED BEARINGS
- STAINLESS MOUNTING FLANGE
- STAINLESS ARBOR
- STAINLESS FASTENERS
- ANSI CLASS 150# FLANGE

AVAILABLE UPGRADES

- ALL STAINLESS MIXER W/CAST STAINLESS HOUSING
- SPECIAL ALLOYS
- SANITARY FINISHES
- SHAFT COATINGS
- THREADED SANITARY COUPLINGS
- RIGID COUPLINGS
- VARIOUS IMPELLER SIZES, STYLES, AND QTY
- DIGITAL TACHOMETER
- TRICLAMP MOUNT
- PNEUMATIC CONTROLS
- FILTER/REGULATOR/LUBRICATOR (FRL)
- LUBE FREE AIR MOTOR

SEAL OPTIONS

LIP SEAL	SINGLE, DOUBLE, VITON, FDA RULON, & MORE
STUFFING BOX	LOW PRESSURE (15 PSI) OR HIGH PRESSURE (150 PSI)
MECHANICAL SEAL	FLOWERVE, CHESTERTON, ROPLAN, & MORE

EST WT. 76-91 LBS (DEPENDING ON HP AND OPTIONS)

TYPICAL IMPELLER OPTIONS

MARINE PROP	PBT - PITCH BLADE TURBINE	PF3 HYDROFOIL	BIOPROP	RUSHTON	COWLES (SAWTOOTH)	FOLDING PROP

NAME	DATE
DRAWN SB	7/18/22
CHECKED MB	8/22/22

PROPRIETARY AND CONFIDENTIAL
 THE INFORMATION CONTAINED IN THIS DRAWING IS THE SOLE PROPERTY OF FUSION FLUID EQUIPMENT LLC. ANY REPRODUCTION IN PART OR AS A WHOLE WITHOUT THE WRITTEN PERMISSION OF FUSION FLUID EQUIPMENT LLC IS PROHIBITED.
 WHILE FUSION FLUID EQUIPMENT LLC STRIVES TO MAINTAIN THE INTEGRITY OF A DESIGN AS APPROVED, FUSION FLUID EQUIPMENT LLC RETAINS THE RIGHT TO MAKE MODIFICATIONS DURING THE MANUFACTURING PROCESS TO IMPROVE FIT, FORM, AND FUNCTION OF THE DESIGN WITHOUT CUSTOMER NOTIFICATION OR CONSENT.
 UNLESS OTHERWISE SPECIFIED: DIMENSIONS ARE IN INCHES. NO TOLERANCE IS IMPLIED.
 DO NOT SCALE DRAWING



TITLE: FUSION PRO PDA-F CLOSED TANK MIXER DIRECT DRIVE AIR		
SIZE DWG. NO. A SALES-PDA-#F-#	REV B	
SCALE: 1:9	WEIGHT:	SHEET 1 OF 1