

BOM			Seal Code					
Position	Description	Material	Type	Size	Rotary Face	Static Face	Secondary Seals	Hardware
1	Rotary Face	SiC/WC-Ni	RT153-x-	x	x	x	x-	x
2	Static Face	C/SiC/WC-Ni		19.05	S6 (SiC)	C (Carbon)	E7 (EPDM Pharma)	C (Complete seal w/out Flush)
3				25.4	T4 (WC-Ni)	S6 (SiC)	F7 (FKM Pharma)	CF (Complete seal w/ Flush)
4	O-Ring	EPDM Pharma FKM Pharma		31.75	7			
5				38.1				
6				50				
7	Drive Ring			50.8				
8	Housing	316L SS		63.5				
9	Sleeve			65				
10	Setup Clip	Aluminum		76.2				
11	Pin	316 SS		80				
12				82.55				
13	Coil Spring			88.9				
14	Guide Pin			90				
15	Set Screw							
16	Screw	304 SS						
17	Circlip	302 SS						
18	Plug	Plastic						

Refer to 13-1290 for part numbers.

Dimensions [Inches]							
Shaft	D1	Bore	OD	L1	L2	BCD	BD
0.750 (19.05 mm)	1.978	2.500	3.500	0.875	1.745	3.063	0.453
1.000 (25.4 mm)	2.228	3.125	4.125		3.750		
1.250 (31.75 mm)	2.478	3.375	4.375		4.000		
1.500 (38.1 mm)	2.728	3.625	4.625	1.825	4.250	0.579	
2.000 (50.8 mm)	3.228	4.125	5.750		4.875		
2.500 (63.5 mm)	3.831	4.625	6.125		5.500		
3.000 (76.2 mm)	4.331	5.125	7.500	1.000	6.250	0.689	
3.250 (82.55 mm)	4.581	5.375	7.750		6.500		
3.500 (88.9 mm)	4.831	5.625	8.000		6.750		

Dimensions [mm]							
Shaft	D1	Bore	OD	L1	L2	BCD	BD
50	82.00	104.78	146.05	22.25	46.35	123.83	14.70
65	97.30	117.48	155.58	139.70			
80	116.35	136.53	196.85	25.40		165.10	
90	122.70	142.88	203.20		171.45	17.50	

Ch.No	Change	Date	Made by	Check. by
6	Added position 18.	2022-01-05	KJW	KJW
7	Added T4 option for rotary face.	2022-01-19	KAV	KJW

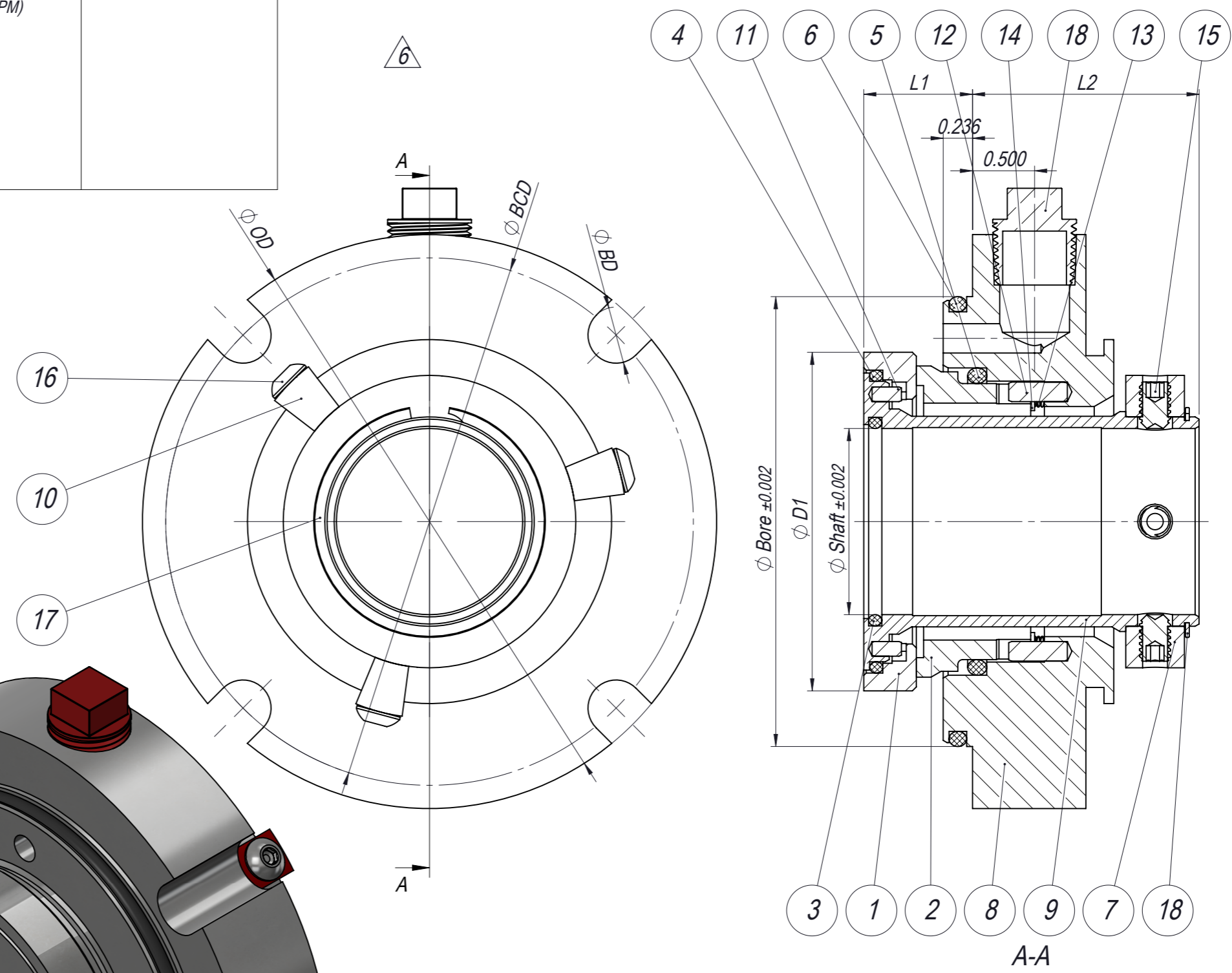

Drawn by KJW	Date 2019-01-24	Description RT153-x-xxx-x Single				
Checked by KJW	Approved by KJW	Applicable to				
Format A3	Scale 1:1	Weight (kg) 2.32	Material	Drawing No. 13-1143	Page 1(1)	Rev. 7
The information contained herein is confidential and proprietary information belonging exclusively to Roplan Holding AB and/or its subsidiary companies, and shall not be used or reproduced in any manner, or disclosed to others without the prior written permission of Roplan Holding AB, or a subsidiary company thereof.				此处所包含信息专属于 Roplan Holding AB 及其附属公司，未经 Roplan Holding AB 及其附属公司书面许可，不得使用或以任何方式转载。		