

MOST COMMON AVAILABLE OPTIONS:

- SINGLE PHASE TEFC MOTOR (≤ 10HP)
- 50 Hz INVERTER DUTY MOTOR
- UP TO 250HP 3 PHASE MOTOR
- SANITARY MOTOR
- EXPLOSION PROOF MOTOR
- ALTERNATE IMPELLER SIZES AND TYPES
- SANITARY FINISHES

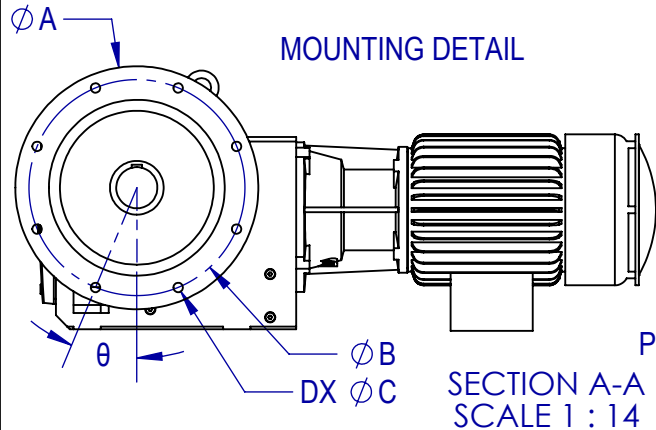

ITEM	DESCRIPTION
1	MOTOR - 230/460/60, 3 PHASE, TEFC STANDARD, INVERTER DUTY (10:1), PAINTED FINISH
2	GEARBOX - HELICAL/BEVEL DRIVE, OUTPUT SPEED PER ORDER, CAST IRON, PAINTED FINISH
3	MOUNT - OPEN TANK MOUNT - SEE TABLE FOR DETAILS
4	SHAFT - LENGTH AND DIAMETER PER ORDER, 316SS TYP.
5	IMPELLER - SIZE, STYLE, & QTY PER ORDER, 316SS TYP.



-# BEARING HOUSING OPTIONS	
-1	HEAVY DUTY/STANDARD SPAN
-2	SPREAD BEARING
-3	SPREAD BEARING/VIRTUAL DRYWELL

DIMENSIONS NOTED ARE APPROXIMATE AND ARE BASED ON TYPICAL MIXER CONFIGURATION. MOTOR SELECTION WILL AFFECT OVERALL LENGTH. PLEASE CONTACT FUSION FOR FURTHER DETAILS.

DIM	TRIPLE REDUCTION									
	FR3-1M	FR3-2M	FR3-3M	FR3-4M	FR3-5M	FR3-7M	FR3-8M	FR3-8.5M	FR3-9M	FR3-9.5M
DIM A (FLANGE)	7.87"	9.84"	11.81"	13.78"	17.72"	21.65"	21.65"	25.98"	25.98"	25.98"
DIM B (B.H.C. DIAMETER)	6.50"	8.47"	10.43"	11.81"	15.75"	19.69"	19.69"	23.62"	23.62"	23.62"
DIM C (BOLT HOLE DIA.)	.43"	.55"	.55"	.71"	.69"	.71"	.71"	.87"	.87"	1.02"
DIM D (# OF HOLES)	4	4	4	4	8	8	8	8	8	8
DIM θ	45°	45°	45°	45°	22.5°	22.5°	22.5°	22.5°	22.5°	22.5°
DIM H	9.8"	11.2"	12.7"	14.5"	17.8"	20.0"	23.1"	28.0"	32.1"	35.8"
DIM L	22.4"	23.2"	28.8"	31.7"	36.8"	45.3"	52.6"	54.7"	58.8"	60.6"

TYPICAL IMPELLER OPTIONS				
BOLTED PF3 HYDROFOIL	BOLTED PBT (PITCH BLADE TURBINE)	RADIAL	RUSHTON	PV3 PROP

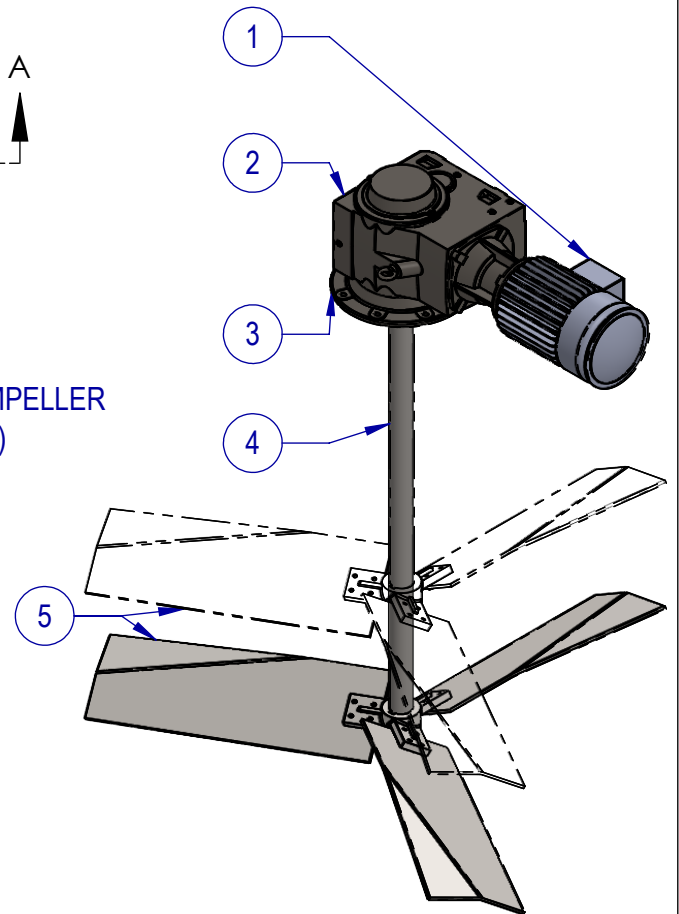
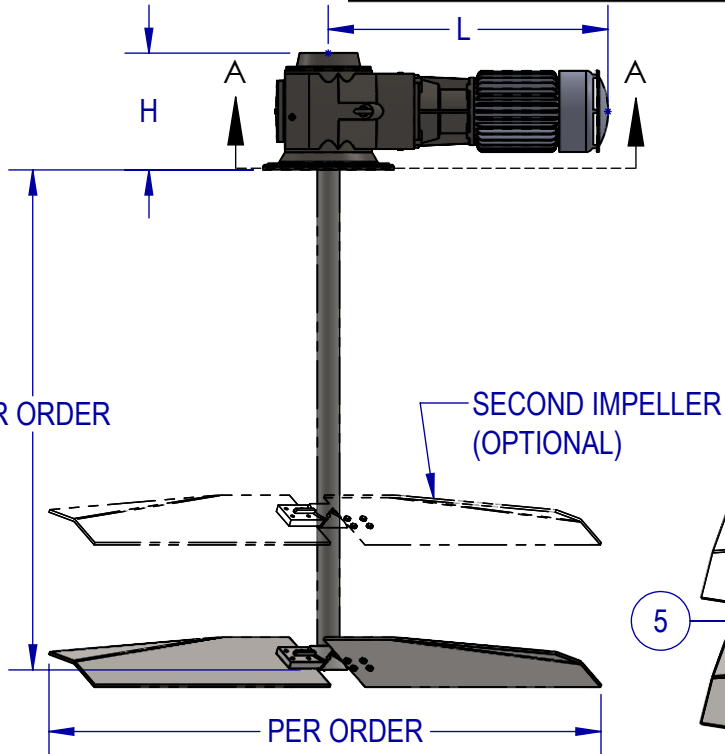

	NAME	DATE
DRAWN	SB	5/27/22
CHECKED	MB	6/24/22

PROPRIETARY AND CONFIDENTIAL

THE INFORMATION CONTAINED IN THIS DRAWING IS THE SOLE PROPERTY OF FUSION FLUID EQUIPMENT LLC. ANY REPRODUCTION IN PART OR AS A WHOLE WITHOUT THE WRITTEN PERMISSION OF FUSION FLUID EQUIPMENT LLC IS PROHIBITED.

UNLESS OTHERWISE SPECIFIED:
DIMENSIONS ARE IN INCHES.
NO TOLERANCES IMPLIED.
DO NOT SCALE DRAWING



TITLE: FUSION FLOW FR3-M TOP ENTRY CIRCULAR MOUNT MIXER HELICAL/BEVEL DRIVE OPEN TANK		
SIZE	DWG. NO.	REV
A	SALES-FR3-#M-#	B
SCALE: 1:24	WEIGHT:	SHEET 1 OF 1