

MOST COMMON AVAILABLE OPTIONS:

- SINGLE PHASE TEFC MOTOR ($\leq 10\text{HP}$)
- 50 Hz INVERTER DUTY MOTOR
- UP TO 250HP 3 PHASE MOTOR
- SANITARY MOTOR
- EXPLOSION PROOF MOTOR
- ALTERNATE IMPELLER SIZES AND TYPES
- SANITARY FINISHES



ITEM	DESCRIPTION
1	MOTOR - 230/460/60, 3 PHASE, TEFC STANDARD, INVERTER DUTY (10:1), PAINTED FINISH
2	GEARBOX - HELICAL/BEVEL DRIVE, OUTPUT SPEED PER ORDER, CAST IRON, PAINTED FINISH
3	MOUNT - OPEN TANK ANGLE MOUNT - CARBON STEEL
4	SHAFT - LENGTH AND DIAMETER PER ORDER, 316SS TYP.
5	IMPELLER - SIZE, STYLE, & QTY PER ORDER, 316SS TYP.

MOUNTING DETAILS

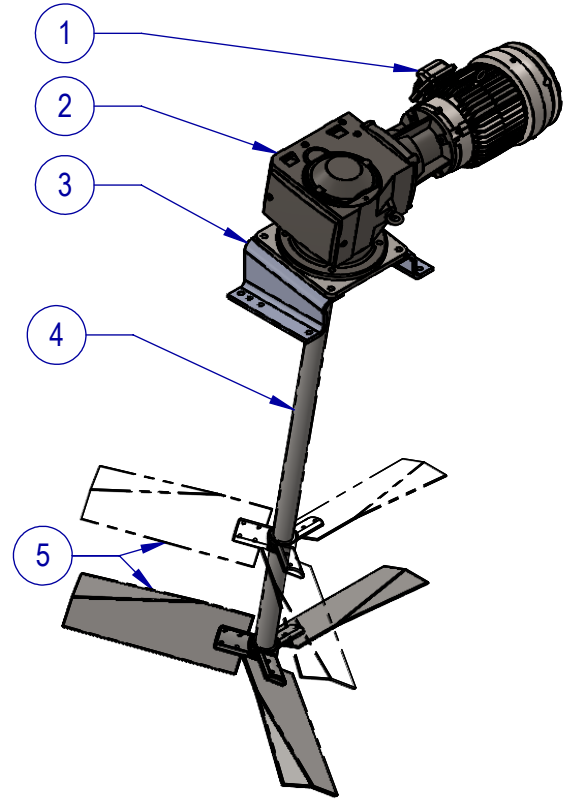
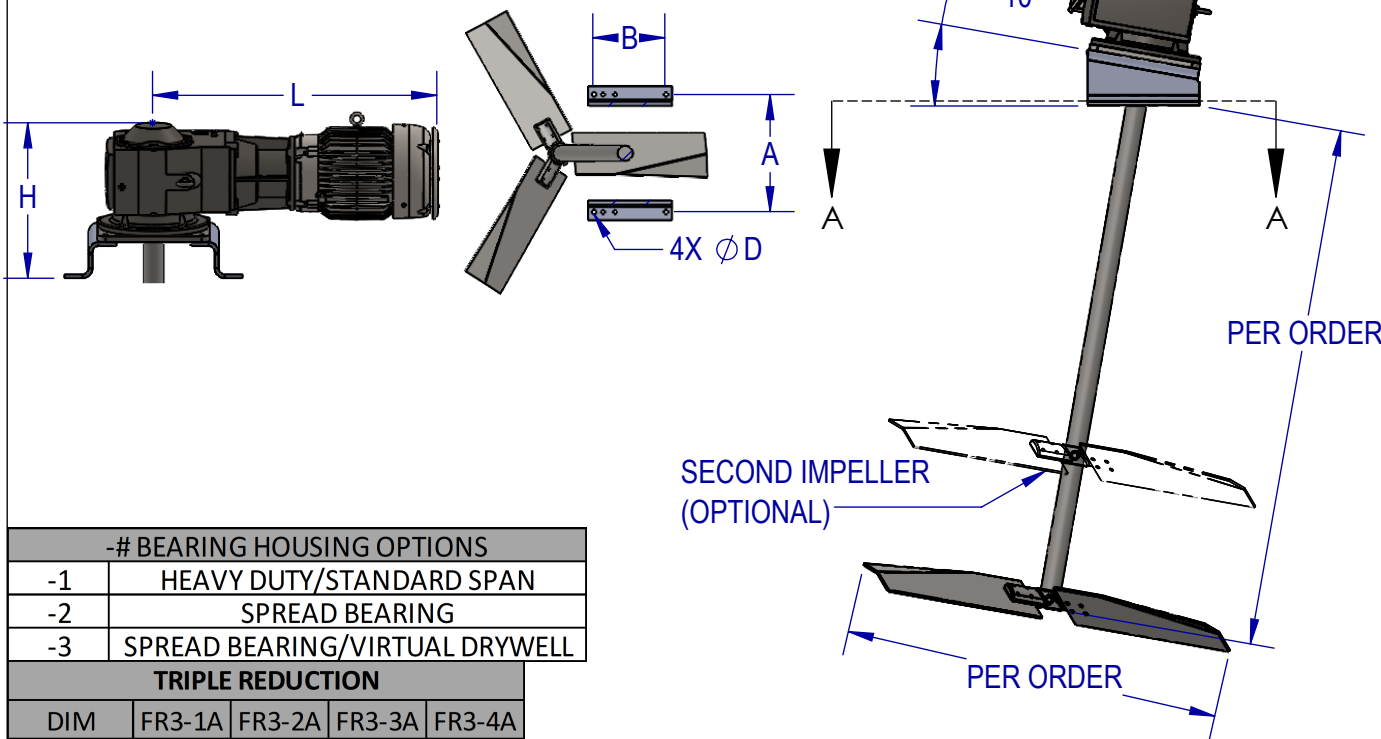

-# BEARING HOUSING OPTIONS	
-1	HEAVY DUTY/STANDARD SPAN
-2	SPREAD BEARING
-3	SPREAD BEARING/VIRTUAL DRYWELL

TRIPLE REDUCTION				
DIM	FR3-1A	FR3-2A	FR3-3A	FR3-4A
DIM A	9.63"	16.02"	16.02"	19.52"
DIM B	6.50"	8.50"	8.50"	12.00"
DIM D	.41"	.61"	.61"	.73"
DIM H	12.3"	18.6"	20.1"	22.2"
DIM L	22.4"	23.2"	28.8"	31.7"

DIMENSIONS NOTED ARE APPROXIMATE AND ARE BASED ON TYPICAL MIXER CONFIGURATION. MOTOR SELECTION WILL AFFECT OVERALL LENGTH. PLEASE CONTACT FUSION FOR FURTHER DETAILS.



TYPICAL IMPELLER OPTIONS				
BOLTED PF3 HYDROFOIL	BOLTED PBT (PITCH BLADE TURBINE)	RADIAL	RUSHTON	PV3 PROP

NAME	DATE
DRAWN SB	5/31/22
CHECKED MB	6/24/22
PROPRIETARY AND CONFIDENTIAL	
UNLESS OTHERWISE SPECIFIED: DIMENSIONS ARE IN INCHES. NO TOLERANCES IMPLIED. DO NOT SCALE DRAWING.	

FUSION FLUID EQUIPMENT	
TITLE: FUSION FLOW FR3-A TOP ENTRY ANGLE MOUNT MIXER HELICAL/BEVEL DRIVE OPEN TANK	
SIZE DWG. NO. A SALES-FR3-#A-#	REV B
SCALE: 1:24 WEIGHT:	SHEET 1 OF 1