

MOST COMMON AVAILABLE OPTIONS:

- SINGLE PHASE TEFC MOTOR (≤ 10HP)
- 50 Hz INVERTER DUTY MOTOR
- UP TO 250HP 3 PHASE MOTOR
- SANITARY MOTOR
- EXPLOSION PROOF MOTOR
- ALTERNATE IMPELLER SIZES AND TYPES
- SANITARY FINISHES

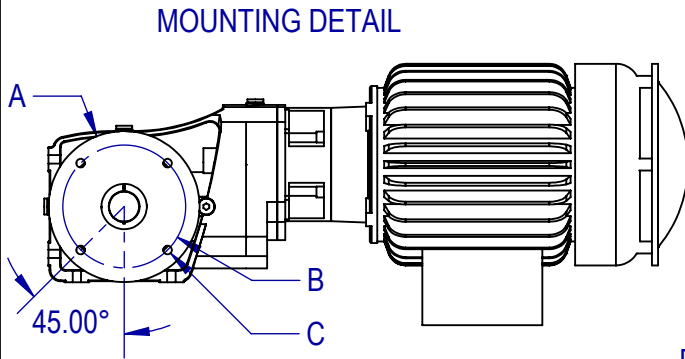

ITEM	DESCRIPTION
1	MOTOR - 230/460/60, 3 PHASE, TEFC STANDARD, INVERTER DUTY (10:1), PAINTED FINISH
2	GEARBOX - HELICAL/BEVEL DRIVE, OUTPUT SPEED PER ORDER, ALUMINUM, PAINTED FINISH
3	MOUNT - OPEN TANK MOUNT - SEE TABLE FOR DETAILS
4	SHAFT - LENGTH AND DIAMETER PER ORDER, 316SS TYP.
5	IMPELLER - SIZE, STYLE, & QTY PER ORDER, 316SS TYP.



SECTION A-A
SCALE 1 : 8

DIMENSIONS NOTED ARE APPROXIMATE AND ARE BASED ON TYPICAL MIXER CONFIGURATION. MOTOR SELECTION WILL AFFECT OVERALL LENGTH. PLEASE CONTACT FUSION FOR FURTHER DETAILS.

DOUBLE REDUCTION					
DIM	FR2E-1M	FR2E-2M	FR2E-3M	FR2E-4M	FR2E-5M
DIM A (FLANGE)	5.51"	6.30"	7.87"	7.87"	9.84"
DIM B (B.H.C. DIAMETER)	4.53"	5.12"	6.50"	6.50"	8.46"
DIM C (BOLT HOLE DIA.)	.35"	.35"	.43"	.43"	.53"
DIM H	6.4"	7.8"	9.5"	10.6"	12.5"
DIM L	19.6"	20.4"	21.8"	26.1"	27.2"

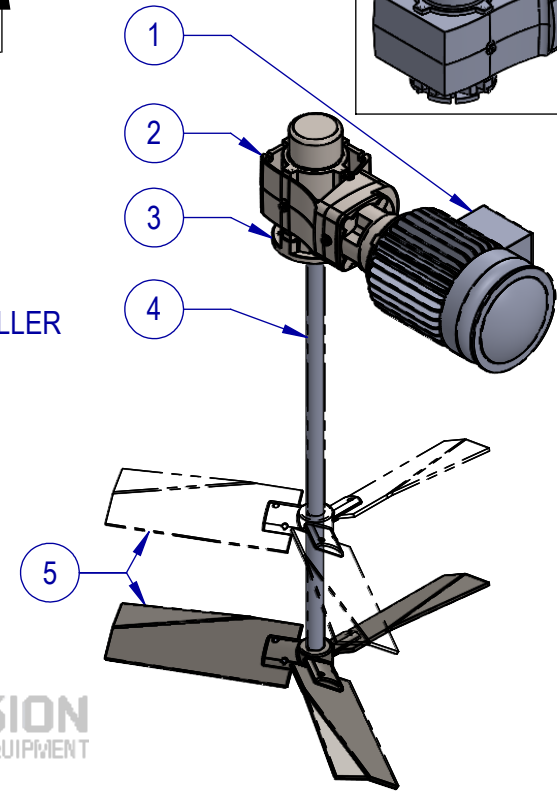
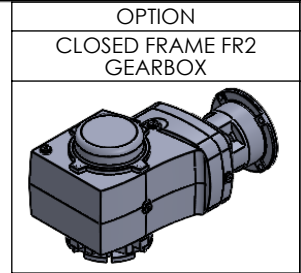
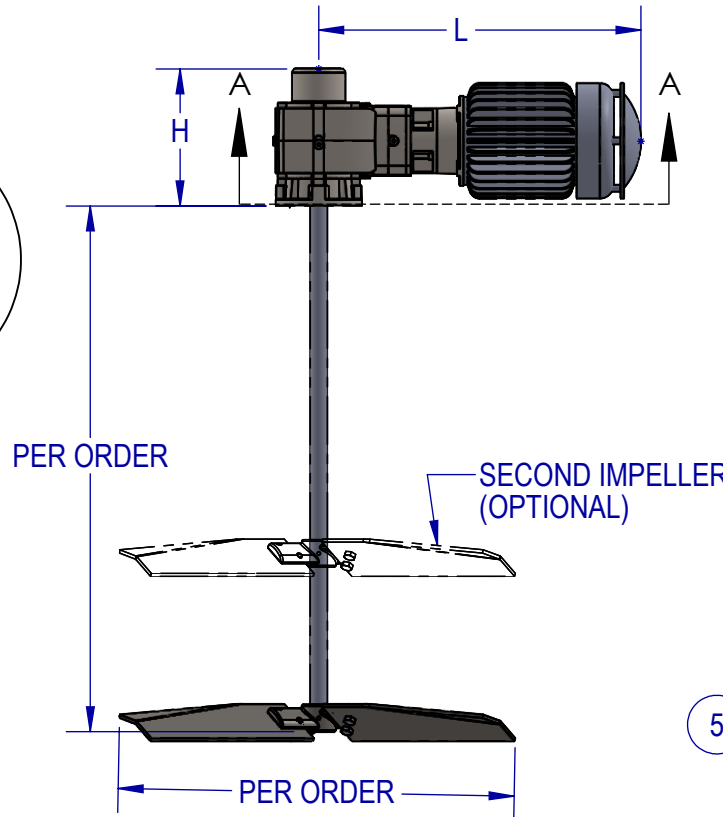

TYPICAL IMPELLER OPTIONS

BOLTED PF3 HYDROFOIL	BOLTED PBT (PITCH BLADE TURBINE)	RADIAL	RUSHTON	PV3 PROP

UNLESS OTHERWISE SPECIFIED:
DIMENSIONS ARE IN INCHES.
NO TOLERANCES IMPLIED.
DO NOT SCALE DRAWING

	NAME	DATE
DRAWN	SB	5/25/22
CHECKED	MB	5/26/22

PROPRIETARY AND CONFIDENTIAL

THE INFORMATION CONTAINED IN THIS DRAWING IS THE SOLE PROPERTY OF FUSION FLUID EQUIPMENT LLC. ANY REPRODUCTION IN PART OR AS A WHOLE WITHOUT THE WRITTEN PERMISSION OF FUSION FLUID EQUIPMENT LLC IS PROHIBITED.



TITLE: FUSION FLOW FR2E-M
TOP ENTRY CIRCULAR MOUNT MIXER
HELICAL/BEVEL DRIVE OPEN TANK

SIZE DWG. NO.	REV
A SALES-FR2E-#M-#	B
SCALE: 1:14 WEIGHT:	SHEET 1 OF 1