

**STANDARD FEATURES:**

- PAINTED AIR MOTOR WITH MUFFLER
- TOTE CAP MOUNT WITH TIE ROD KIT
- 316SS WETTED PARTS
- 3/4" X 36" FMB SHAFT STANDARD
- SINGLE OR DUAL MARINE IMPELLERS WITH SET SCREW ATTACHMENT
- SPEED CONTROL VALVE

**OPTIONAL FEATURES:**

- PNEUMATIC CONTROLS
- FILTER/REGULATOR/LUBRICATOR (FRL)
- ALTERNATE IMPELLER SIZES AND TYPES
- ALL STAINLESS STEEL UPGRADE WITH STAINLESS MOTOR, STAINLESS MOUNT & STAINLESS HARDWARE
- SANITARY FINISHES

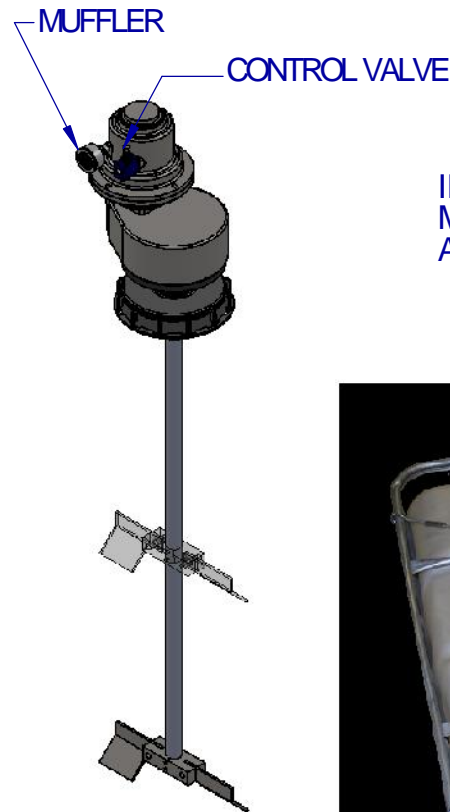
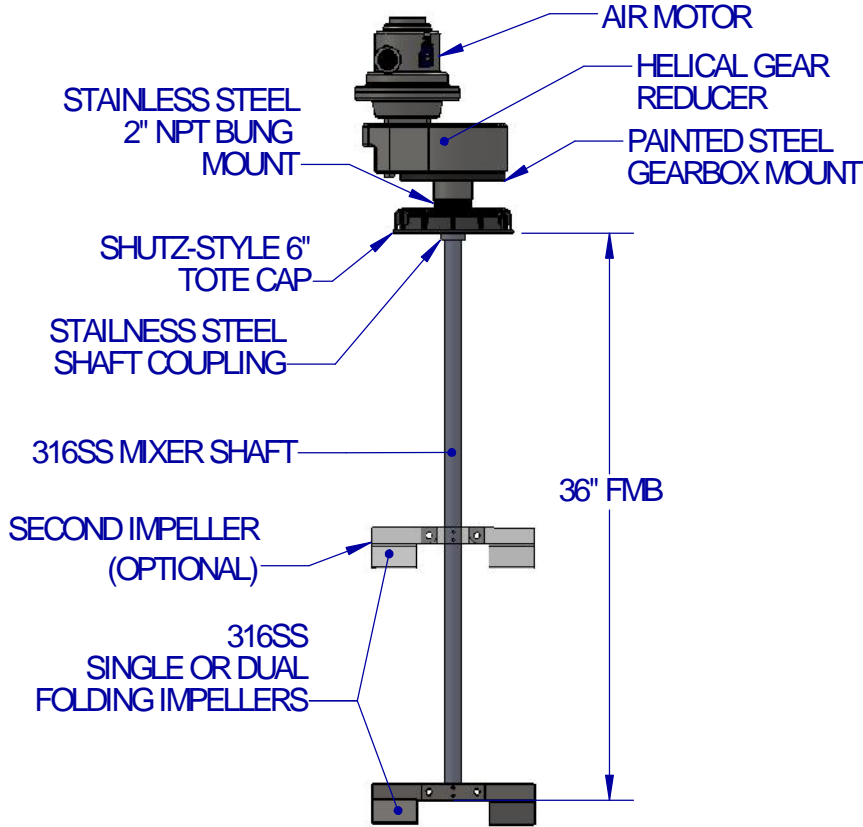

INCLUDES TIE ROD MOUNTING KIT FOR ADDED STABILITY



| AIR CONSUMPTION |                  |
|-----------------|------------------|
| 1 HP            | 40 CFM @ 80 PSI  |
| 2 HP            | 60 CFM @ 70 PSI  |
| 3 HP            | 90 CFM @ 100 PSI |

| NAME        | DATE    |
|-------------|---------|
| DRAWN JDF   | 12/2/13 |
| CHECKED PIC | 12/2/13 |

PROPRIETARY AND CONFIDENTIAL  
 THE INFORMATION CONTAINED IN THIS DRAWING IS THE SOLE PROPERTY OF FUSION FLUID EQUIPMENT LLC. ANY REPRODUCTION IN PART OR AS A WHOLE WITHOUT THE WRITTEN PERMISSION OF FUSION FLUID EQUIPMENT LLC IS PROHIBITED.



TITLE: TOTE CAP MOUNTED TOE MIXER GEAR DRIVE AIR MOTOR

EST. WT.: 51-67 LBS (DEPENDING ON HP AND OPTIONS)

UNLESS OTHERWISE SPECIFIED:  
 DIMENSIONS ARE IN INCHES.  
 NO TOLERANCE IS IMPLIED.  
 DO NOT SCALE DRAWING

WHILE FUSION FLUID EQUIPMENT LLC STRIVES TO MAINTAIN THE INTEGRITY OF A DESIGN AS APPROVED, FUSION FLUID EQUIPMENT LLC RETAINS THE RIGHT TO MAKE MODIFICATIONS DURING THE MANUFACTURING PROCESS TO IMPROVE FIT, FORM, AND FUNCTION OF THE DESIGN WITHOUT CUSTOMER NOTIFICATION OR CONSENT.

| SIZE        | DWG. NO.     | REV          |
|-------------|--------------|--------------|
| A           | SALES-BGA-#J | A            |
| SCALE: 1:16 | WEIGHT:      | SHEET 1 OF 1 |