

STANDARD FEATURES:

- PAINTED THREE PHASE 208-220/440/60 ELECTRIC MOTOR
- HELICAL GEARBOX - 5:1 REDUCTION RATIO
- 350 RPM NOMINAL OUTPUT
- TOTE CAP MOUNT WITH TIE ROD MOUNTING KIT
- 316SS WETTED PARTS
- 1" X 36" FMB SHAFT STANDARD
- SINGLE OR DUAL FOLDING IMPELLERS WITH SET SCREW ATTACHMENT

OPTIONS:

- SINGLE PHASE TEFC MOTOR
- EXLOSION PROOF MOTOR
- ALTERNATE IMPELLER SIZES AND TYPES
- ALL STAINLESS STEEL UPGRADE WITH STAINLESS MOTOR, STAINLESS MOUNT & STAINLESS FASTENERS
- SANITARY FINISHES

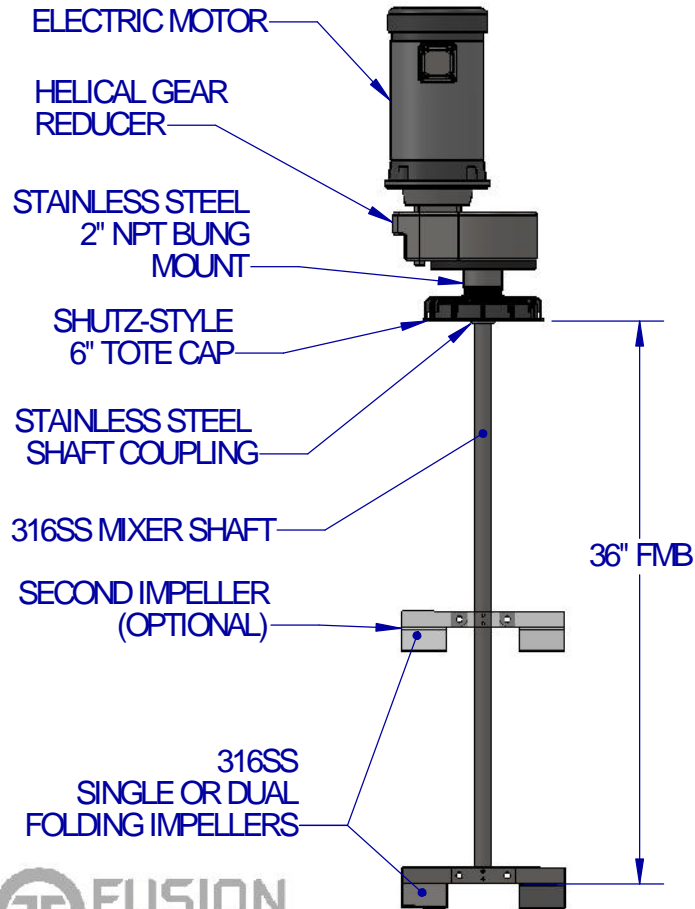

INCLUDES TIE ROD MOUNTING KIT FOR ADDED STABILITY

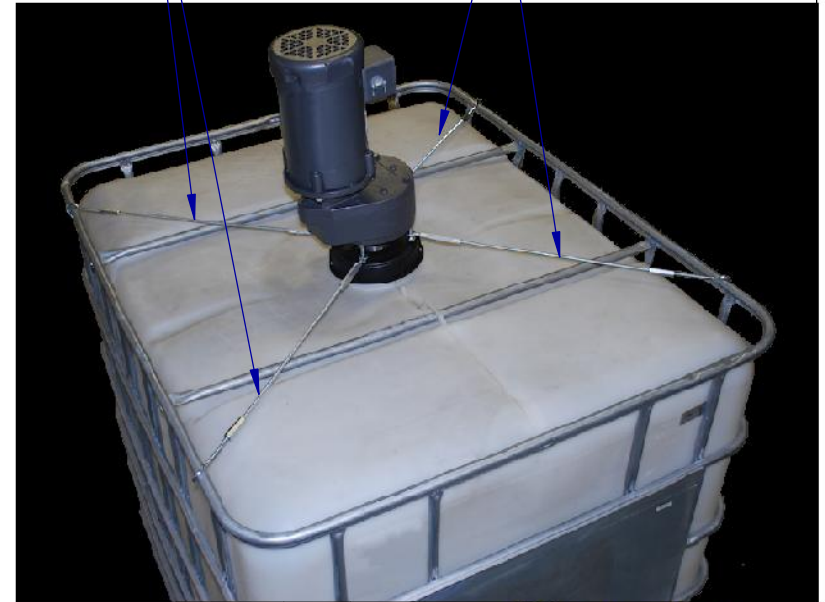

EST WT: 65-149 LBS (DEPENDING ON HP AND OPTIONS)

	NAME	DATE
DRAWN	JDF	12/2/13
CHECKED	PIC	12/2/13

PROPRIETARY AND CONFIDENTIAL

THE INFORMATION CONTAINED IN THIS DRAWING IS THE SOLE PROPERTY OF FUSION FLUID EQUIPMENT LLC. ANY REPRODUCTION IN PART OR AS A WHOLE WITHOUT THE WRITTEN PERMISSION OF FUSION FLUID EQUIPMENT LLC IS PROHIBITED.

WHILE FUSION FLUID EQUIPMENT LLC STRIVES TO MAINTAIN THE INTEGRITY OF A DESIGN AS APPROVED, FUSION FLUID EQUIPMENT LLC RETAINS THE RIGHT TO MAKE MODIFICATIONS DURING THE MANUFACTURING PROCESS TO IMPROVE FIT, FORM, AND FUNCTION OF THE DESIGN WITHOUT CUSTOMER NOTIFICATION OR CONSENT.

UNLESS OTHERWISE SPECIFIED:
DIMENSIONS ARE IN INCHES.
NO TOLERANCE IS IMPLIED.
DO NOT SCALE DRAWING



TITLE: TOTE CAP MOUNTED TOTE MIXER GEAR DRIVE ELECTRIC

SIZE	DWG. NO.	REV
A	SALES-BG-#J-#	A
SCALE: 1:16	WEIGHT:	SHEET 1 OF 1