

STANDARD FEATURES:

- PAINTED THREE PHASE 208-220/440/60 ELECTRIC MOTOR
- 1750 RPM NOMINAL
- TOTE CAP MOUNT WITH TIE ROD KIT
- 316SS WETTED PARTS
- 3/4" X 36" FMB SHAFT STANDARD
- SINGLE OR DUAL MARINE IMPELLERS WITH SET SCREW ATTACHMENT

OPTIONAL FEATURES:

- SINGLE PHASE INPUT
- EXPLOSION PROOF MOTOR
- ALTERNATE IMPELLER SIZES AND TYPES
- ALL STAINLESS STEEL UPGRADE WITH STAINLESS MOTOR, STAINLESS MOUNT & STAINLESS FASTENERS
- SANITARY FINISHES

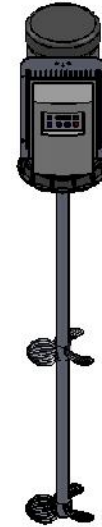
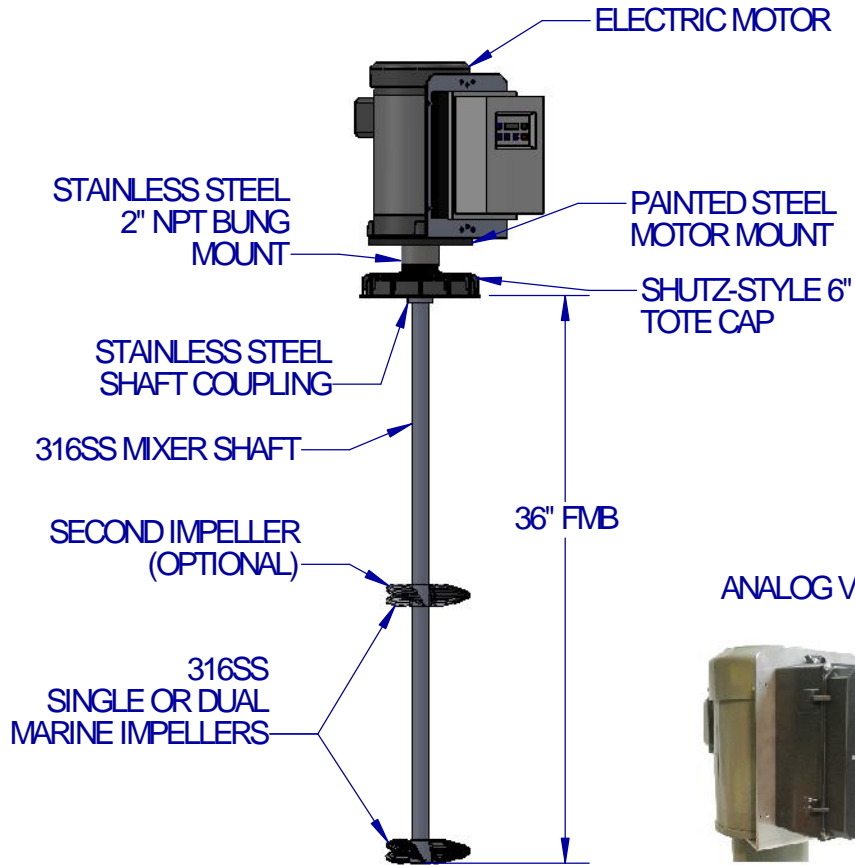

INCLUDES TIE ROD MOUNTING KIT FOR ADDED STABILITY



ANALOG VFD

DIGITAL VFD



EST WT: 46-64 LBS (DEPENDING ON HP AND OPTIONS)

SPEED TABLE		NAME	DATE
1750 RPM	STANDARD	JDF	12/2/13
1150 RPM	OPTIONAL	PIC	12/2/13
3600 RPM	OPTIONAL		
UNLESS OTHERWISE SPECIFIED: DIMENSIONS ARE IN INCHES. NO TOLERANCE IS IMPLIED. DO NOT SCALE DRAWING			

PROPRIETARY AND CONFIDENTIAL
 THE INFORMATION CONTAINED IN THIS DRAWING IS THE SOLE PROPERTY OF FUSION FLUID EQUIPMENT LLC. ANY REPRODUCTION IN PART OR AS A WHOLE WITHOUT THE WRITTEN PERMISSION OF FUSION FLUID EQUIPMENT LLC IS PROHIBITED.
 WHILE FUSION FLUID EQUIPMENT LLC STRIVES TO MAINTAIN THE INTEGRITY OF A DESIGN AS APPROVED, FUSION FLUID EQUIPMENT LLC RETAINS THE RIGHT TO MAKE MODIFICATIONS DURING THE MANUFACTURING PROCESS TO IMPROVE FIT, FORM, AND FUNCTION OF THE DESIGN WITHOUT CUSTOMER NOTIFICATION OR CONSENT.



TITLE: TOTE CAP MOUNTED MIXER DIRECT DRIVE ELECTRIC		
SIZE A	DWG. NO. SALES-BD-#J-#-V#	REV A
SCALE: 1:48	WEIGHT:	SHEET 2 OF 1