

**STANDARD FEATURES:**

- PAINTED, THREE PHASE, TEFC, 208-230/460/60 ELECTRIC MOTOR (PER ORDER)
- HELICAL GEARBOX - 5:1 REDUCTION RATIO  
350 RPM NOMINAL OUTPUT
- ADJUSTABLE BRIDGE MOUNT
- 316SS WETTED PARTS
- 1" X 36" FMB SHAFT STANDARD
- SINGLE OR DUAL FOLDING IMPELLERS WITH SET SCREW ATTACHMENT
- ANALOG SPEED CONTROL (VFD)

SPEED TABLE	
350 RPM	STANDARD
230 RPM	OPTIONAL
438 RPM	OPTIONAL

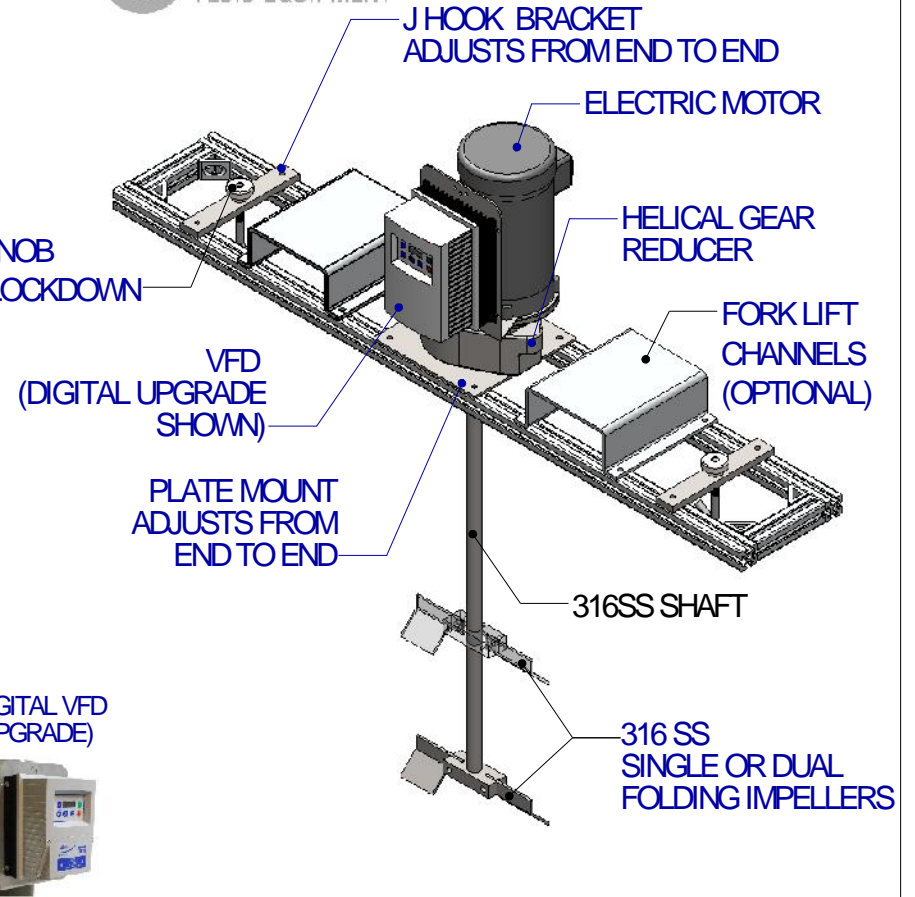
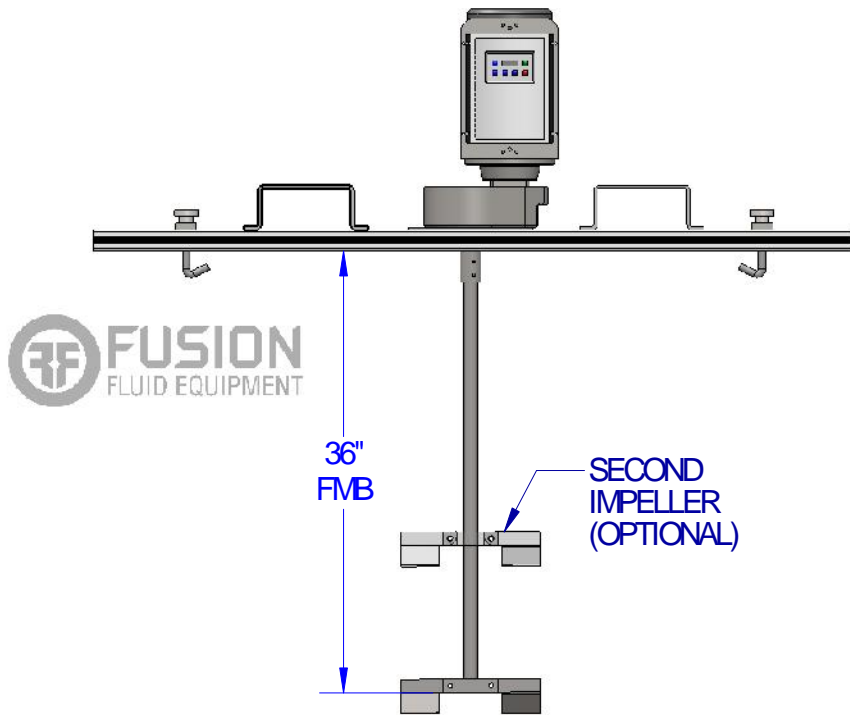

ANALOG VFD (STANDARD)    DIGITAL VFD (UPGRADE)



**OPTIONAL FEATURES:**

- SINGLE PHASE INPUT
- ALL STAINLESS STEEL UPGRADE WITH STAINLESS MOTOR, MOUNT & FASTENERS
- FORKLIFT CHANNELS
- SANITARY FINISHES
- FLOATING TOTE CAP WITH LIP SEAL
- DIGITAL SPEED CONTROL (VFD)

**BRIDGE MOUNT TOTE MIXERS MOUNT TO CAGE STYLE TOTES UP TO 52" WIDE**

EST WT: 84-170 LBS (DEPENDING ON HP AND OPTIONS)

NAME	DATE
DRAWN JM	6/8/15
CHECKED PIC	

PROPRIETARY AND CONFIDENTIAL

THE INFORMATION CONTAINED IN THIS DRAWING IS THE SOLE PROPERTY OF FUSION FLUID EQUIPMENT LLC. ANY REPRODUCTION IN PART OR AS A WHOLE WITHOUT THE WRITTEN PERMISSION OF FUSION FLUID EQUIPMENT LLC IS PROHIBITED.

WHILE FUSION FLUID EQUIPMENT LLC STRIVES TO MAINTAIN THE INTEGRITY OF A DESIGN AS APPROVED, FUSION FLUID EQUIPMENT LLC RETAINS THE RIGHT TO MAKE MODIFICATIONS DURING THE MANUFACTURING PROCESS TO IMPROVE FIT, FORM, AND FUNCTION OF THE DESIGN WITHOUT CUSTOMER NOTIFICATION OR CONSENT.

UNLESS OTHERWISE SPECIFIED:  
DIMENSIONS ARE IN INCHES.  
NO TOLERANCE IS IMPLIED.  
DO NOT SCALE DRAWING



TITLE: BRIDGE MOUNT TOTE MIXER GEAR DRIVE ELECTRIC WITH VFD

SIZE	DWG. NO.	REV
A	SALES-BG-#T-#-V#	A
SCALE: 1:16 WEIGHT:		SHEET 1 OF 1