

STANDARD FEATURES:

- PAINTED THREE PHASE 208-230/480/60 ELECTRIC MOTOR
- 55 GALLON DRUM LID WITH TWO STANDARD NPT PORTS
- 316SS WETTED PARTS
- 3/4" X 30" FMB SHAFT STANDARD (UP TO 36" MAX)
- SINGLE OR DUAL MARINE IMPELLERS
- WITH SET SCREW ATTACHMENT

OPTIONAL FEATURES:

- SINGLE PHASE INPUT
- EXPLOSION PROOF MOTOR
- ALTERNATE IMPELLER SIZES AND TYPES
- ALL STAINLESS STEEL UPGRADE WITH STAINLESS MOTOR, STAINLESS MOUNT & STAINLESS FASTENERS
- SANITARY FINISHES

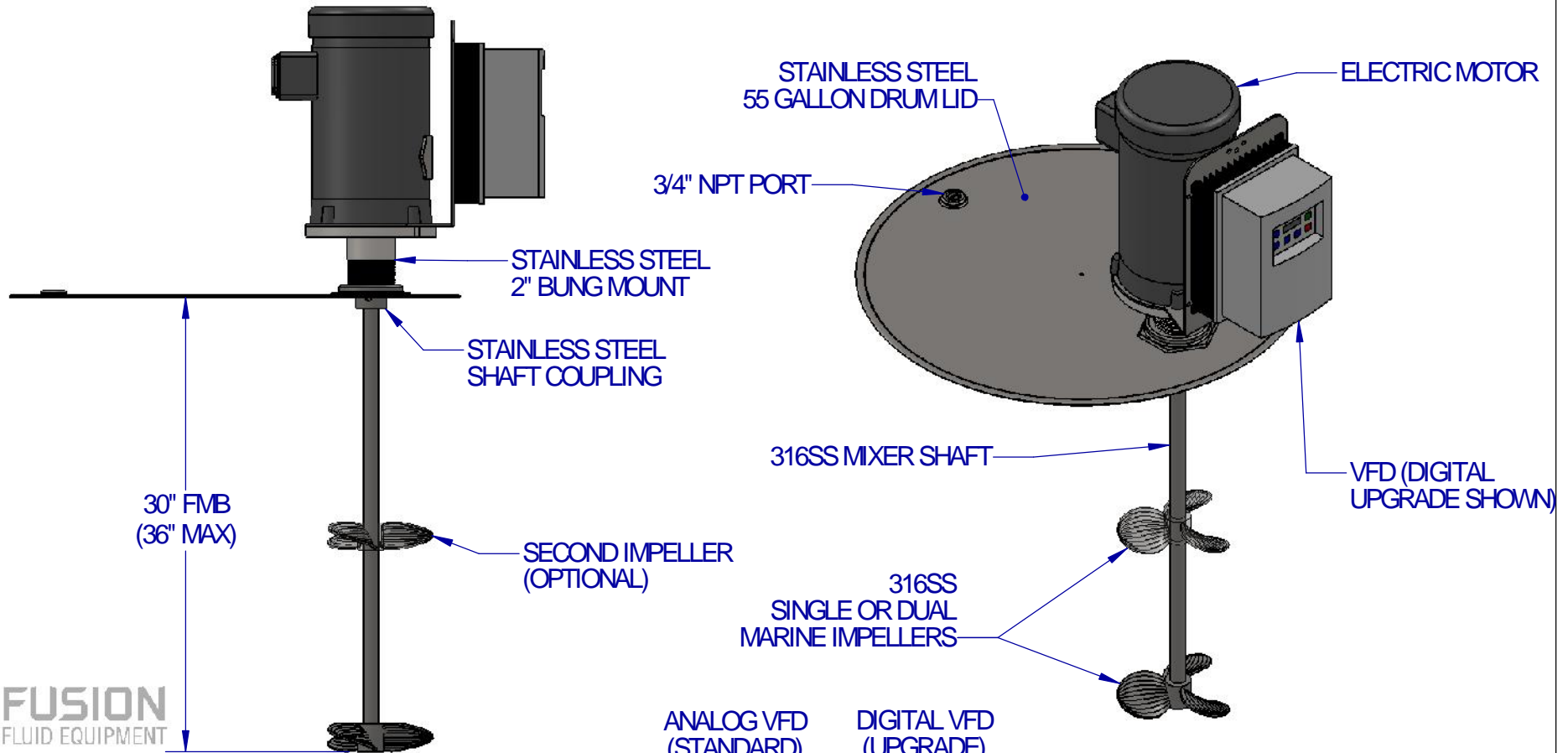

EST WT: 56-79 LBS (DEPENDING ON HP AND OPTIONS)

ANALOG VFD (STANDARD)

DIGITAL VFD (UPGRADE)



	NAME	DATE
DRAWN	JDF	12/2/13
CHECKED	TS	12/2/13

PROPRIETARY AND CONFIDENTIAL

THE INFORMATION CONTAINED IN THIS DRAWING IS THE SOLE PROPERTY OF FUSION FLUID EQUIPMENT LLC. ANY REPRODUCTION IN PART OR AS A WHOLE WITHOUT THE WRITTEN PERMISSION OF FUSION FLUID EQUIPMENT LLC IS PROHIBITED.

WHILE FUSION FLUID EQUIPMENT LLC STRIVES TO MAINTAIN THE INTEGRITY OF A DESIGN AS APPROVED, FUSION FLUID EQUIPMENT LLC RETAINS THE RIGHT TO MAKE MODIFICATIONS DURING THE MANUFACTURING PROCESS TO IMPROVE FIT, FORM, AND FUNCTION OF THE DESIGN WITHOUT CUSTOMER NOTIFICATION OR CONSENT.

UNLESS OTHERWISE SPECIFIED:
DIMENSIONS ARE IN INCHES.
NO TOLERANCE IS IMPLIED.
DO NOT SCALE DRAWING

FUSION FLUID EQUIPMENT		TITLE: DRUM LID MIXER BUNG MOUNT DIRECT DRIVE ELECTRIC WITH VFD	
SIZE A	DWG. NO. SALES-BD-#D-#-V#	REV A	
SCALE: 1:48	WEIGHT:	SHEET 1 OF 1	