

STANDARD FEATURES:
 PAINTED AIR MOTOR WITH MUFFLER
 316SS WETTED PARTS
 3/4" X 30" FMB SHAFT (UP TO 36" MAX)
 SINGLE OR DUAL FOLDING IMPELLERS
 WITH SET SCREW ATTACHMENT
 SPEED CONTROL VALVE

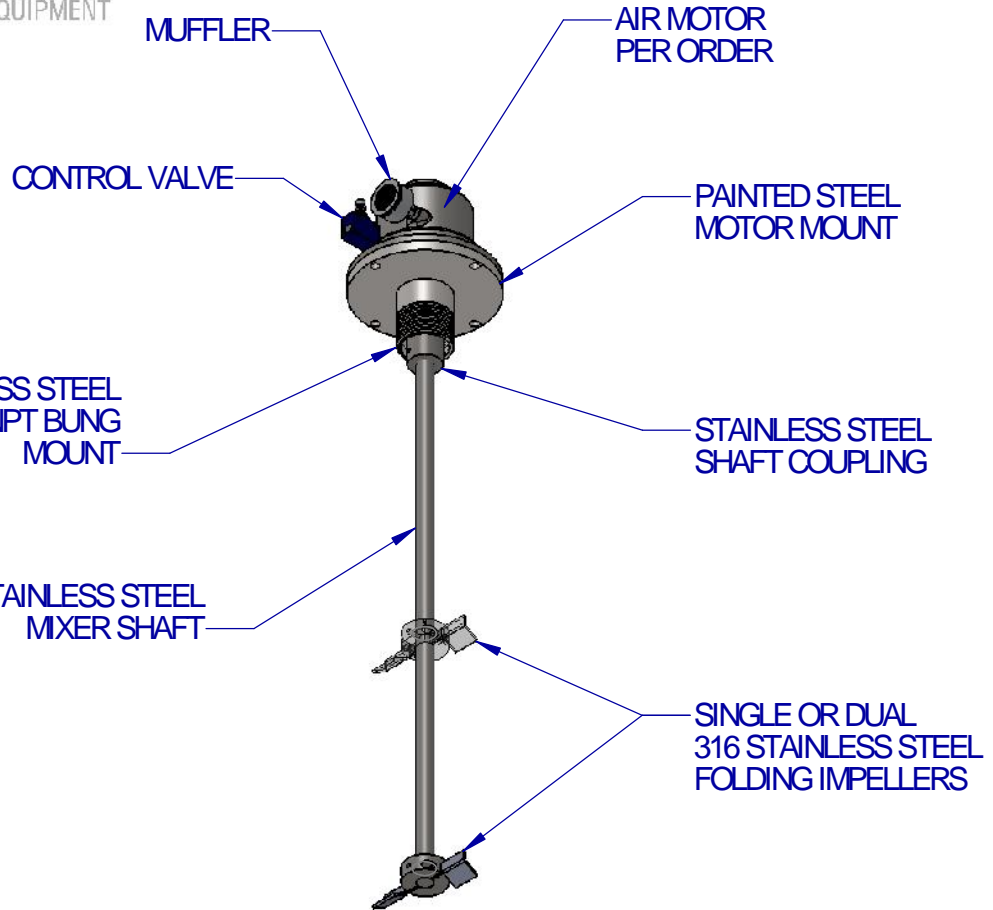

OPTIONAL SECOND IMPELLER

30" FMB



OPTIONS:
 PNEUMATIC CONTROLS
 FILTER, LUBRICATOR, AND REGULATOR
 ALTERNATE IMPELLER SIZES AND TYPES
 ALL STAINLESS STEEL UPGRADE WITH STAINLESS MOTOR,
 STAINLESS MOUNT & STAINLESS FASTENERS
 SANITARY FINISHES

EST WT: 27-46 LBS (DEPENDING ON HP AND OPTIONS)

AIR CONSUMPTION	
1 HP	40 CFM @ 80 PSI
2 HP	60 CFM @ 70 PSI
3 HP	90 CFM @ 100 PSI

NAME	DATE
DRAWN JDF	11/27/13
CHECKED PIC	11/27/13

PROPRIETARY AND CONFIDENTIAL
 THE INFORMATION CONTAINED IN THIS DRAWING IS THE SOLE PROPERTY OF FUSION FLUID EQUIPMENT LLC. ANY REPRODUCTION IN PART OR AS A WHOLE WITHOUT THE WRITTEN PERMISSION OF FUSION FLUID EQUIPMENT LLC IS PROHIBITED.

WHILE FUSION FLUID EQUIPMENT LLC STRIVES TO MAINTAIN THE INTEGRITY OF A DESIGN AS APPROVED, FUSION FLUID EQUIPMENT LLC RETAINS THE RIGHT TO MAKE MODIFICATIONS DURING THE MANUFACTURING PROCESS TO IMPROVE FIT, FORM, AND FUNCTION OF THE DESIGN WITHOUT CUSTOMER NOTIFICATION OR CONSENT.

UNLESS OTHERWISE SPECIFIED:
 DIMENSIONS ARE IN INCHES.
 NO TOLERANCE IS IMPLIED.
 DO NOT SCALE DRAWING



TITLE:
**BUNG MOUNT DRUM MIXER
 DIRECT DRIVE AIR**

SIZE	DWG. NO.	REV
A	SALES-BDA-#B	A
SCALE: 1:12		WEIGHT:
		SHEET 1 OF 1