

STANDARD FEATURES:

- WASHDOWN DUTY, STAINLESS STEEL, ELECTRIC MOTOR,
- THREE PHASE 220/440/60, 1750 RPM NOMINAL
- STAINLESS STEEL TRICLAMP PEDESTAL WITH ACCESS WINDOW
- 316SS WETTED PARTS - MILL/CAST FINISH
- 3/4" MIXER SHAFT - LENGTH TO FIT (UP TO 72" MAX)
- SINGLE OR DUAL MARINE IMPELLERS
- WITH SET SCREW OR WELDED ATTACHMENT

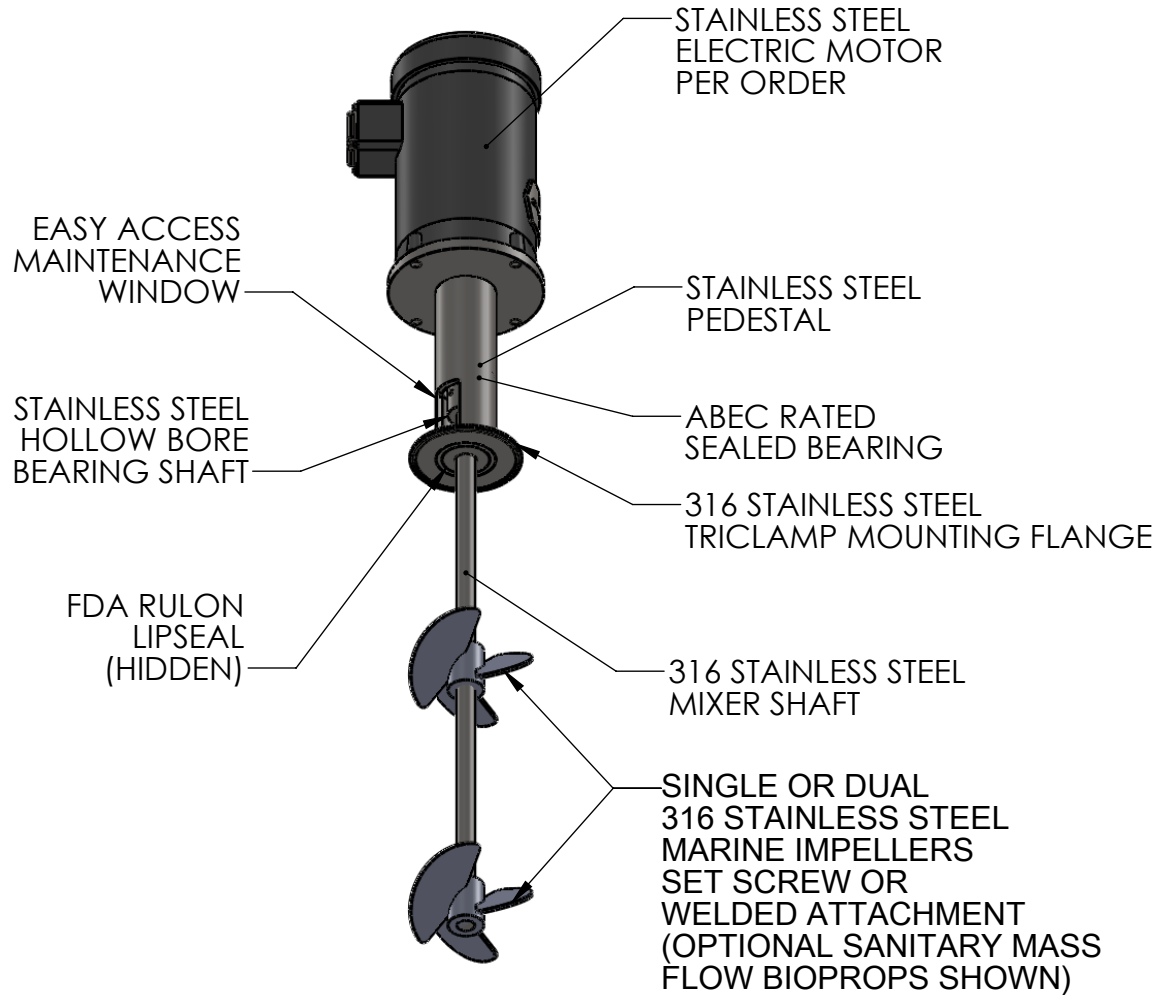
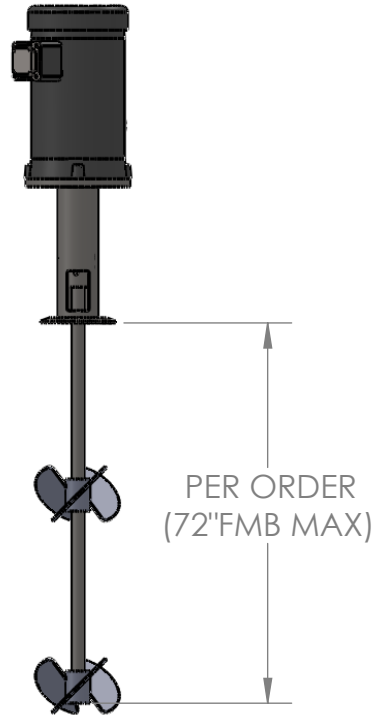

OPTIONS:

- SINGLE PHASE TEFC MOTOR
- EXLOSION PROOF MOTOR
- AIR MOTOR
- VITON OR EPDM LIPSEAL
- MECHANICAL SEAL (MODEL# PHD-FM)
- SANITARY FINISHING OPTIONS
- ALTERNATE IMPELLER SIZES AND TYPES
- (SANITARY BIOPROP RECOMMENDED)

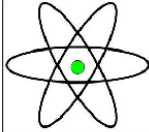
<small>UNLESS OTHERWISE SPECIFIED: DIMENSIONS ARE IN INCHES REMOVE BURRS AND BREAK SHARP EDGES .005 - .015 WELDS TO BE CONTINUOUS AND FREE OF VIDS & CRACKS</small>	SIGNATURE & DATE		 Fusion Fluid Equipment_{uc}
	DRAWN	PIC	
	CHKR	TS	
	JOB NO.	N/A	
	MATERIAL:	AS REQ'D	
TREATMENT:	N/A	DWG TITLE	PHD-FL - PURE HD DIRECT DRIVE MIXER - ELECTRIC
SCALE	N/A	SHEET 1 OF 1	SIZE A DWG. NO. 000000